

# 인터넷 만들기

고양우

*We reject: kings, presidents and voting.  
We believe in: **rough consensus** and  
**running code**. – David D. Clark*

관리자@오픈넷.KR

RFC6530 / RFC6531 / RFC6532 / RFC6533

RFC5890 / RFC5891 / RFC3743 / RFC4290

THE FIFTY-THIRD  
INTERNET ENGINEERING TASK FORCE  
Hosted by Cable and Wireless  
Minneapolis, Minnesota USA  
March 17 – 22, 2002

2.1.18 Keywords Naming Services (kwns) Bof  
Current Meeting Report  
[kwns BOF]

Co-Chair **YangWoo Ko** introduces charter, defines  
"Keywords" for the purpose of this meeting:

- Keywords are defined as internationalized string for internet navigation.
- Charter highlights – direct navigation is very desirable for users –users wish to use keywords as unambiguous addresses

# WHO RUNS THE INTERNET?

## NO ONE PERSON, COMPANY, ORGANIZATION OR GOVERNMENT RUNS THE INTERNET.

The Internet itself is a globally distributed computer network comprised of many voluntarily interconnected autonomous networks. Similarly, its governance is conducted by a decentralized and international multi-stakeholder network of interconnected autonomous groups drawing from civil society, the private sector, governments, the academic and research communities, and national and international organizations. They work cooperatively from their respective roles to create shared policies and standards that maintain the Internet's global interoperability for the public good.

### WHO IS INVOLVED:

- IAB** **A C P S R**  
INTERNET ARCHITECTURE BOARD  
Oversees the technical and engineering development of the IETF and IRTF.  
[www.iab.org](http://www.iab.org)
- ICANN** **C O C P V**  
INTERNET CORPORATION FOR ASSIGNED NAMES AND NUMBERS  
Coordinates the Internet's systems of unique identifiers: IP addresses, Protocol-Parameter registries, top-level domain space (DNS root zone).  
[www.icann.org](http://www.icann.org)
- IETF** **C P S**  
INTERNET ENGINEERING TASK FORCE  
Develops and promotes a wide range of Internet standards dealing in particular with standards of the Internet protocol suite. Their technical documents influence the way people design, use, and manage the Internet.  
[www.ietf.org](http://www.ietf.org)
- IGF** **A C P P**  
INTERNET GOVERNANCE FORUM  
A multi-stakeholder open forum for debate on issues related to internet governance.  
[www.intgovforum.org](http://www.intgovforum.org)
- IRTF** **R**  
INTERNET RESEARCH TASK FORCE  
Promotes research of the evolution of the Internet by creating focused, long-term research groups working on topics related to Internet protocols, applications, architecture and technology.  
[www.irtf.org](http://www.irtf.org)
- GOVERNMENTS AND INTER-GOVERNMENTAL ORGANIZATIONS** **C P**  
Develop laws, regulations and policies applicable to the Internet within their jurisdictions; participants in multilateral and multi-stakeholder regional and international fora on Internet Governance.

### HERE IS HOW IT WORKS:

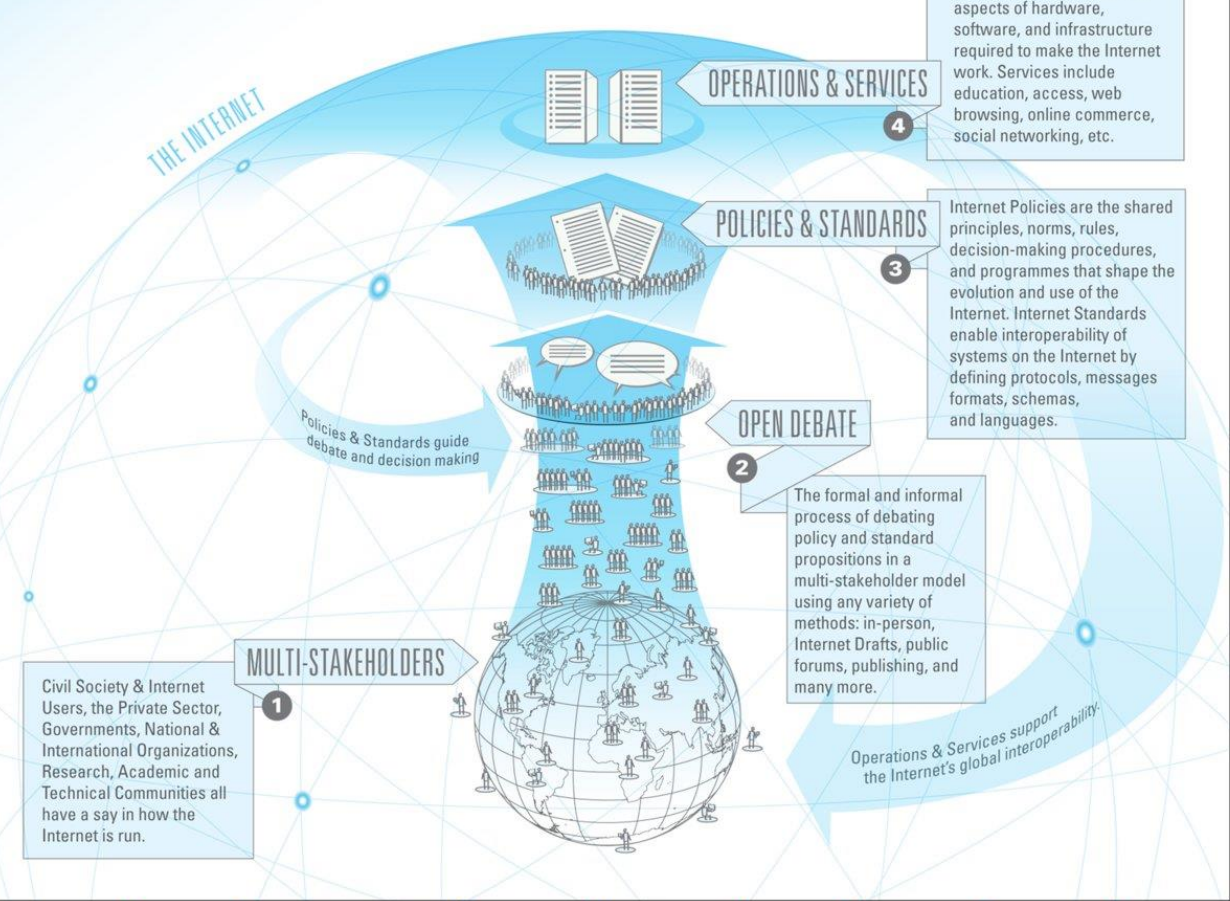

LEGEND: **A** Advice **C** Community Engagement **E** Education **O** Operations **P** Policy **R** Research **S** Standards **V** Services

### WHO IS INVOLVED:

- ISO 3166 MA** **S**  
INTERNATIONAL ORGANIZATION FOR STANDARDIZATION, MAINTENANCE AGENCY  
Defines names and postal codes of countries, dependent territories, special areas of geographic significance.  
[www.iso.org/iso/country\\_codes.htm](http://www.iso.org/iso/country_codes.htm)
- ISOC** **C E P V**  
INTERNET SOCIETY  
Assure the open development, evolution and use of the Internet for the benefit of all people throughout the world. Currently ISOC has over 90 chapters in around 80 countries.  
[www.internetsociety.org](http://www.internetsociety.org)
- RIRs** **D P V**  
5 REGIONAL INTERNET REGISTRIES  
Manage the allocation and registration of Internet number resources, such as IP addresses, within geographic regions of the world.  
[www.afrinic.net](http://www.afrinic.net) Africa  
[www.apnic.net](http://www.apnic.net) Asia Pacific  
[www.arin.net](http://www.arin.net) Canada & United States  
[www.lacnic.net](http://www.lacnic.net) Latin America & Caribbean  
[www.ripe.net](http://www.ripe.net) Europe, the Middle East & parts of Central Asia
- W3C** **S**  
WORLD WIDE WEB CONSORTIUM  
Create standards for the world wide web that enable an Open Web Platform, for example, by focusing on issues of accessibility, internationalization, and mobile web solutions.  
[www.w3.org](http://www.w3.org)
- INTERNET NETWORK OPERATORS' GROUPS** **A O V**  
Discuss and influence matters related to Internet operations and regulation within informal fora made up of Internet Service Providers (ISPs), Internet Exchange Points (IXPs) and others.

This graphic is a living document, designed to provide a high level view of how the internet is run. It is not intended to be a definitive guide. Please provide feedback at [www.xplanations.com/whorunsinternet](http://www.xplanations.com/whorunsinternet)



인터넷을 왜  
만들었을까?

1장에 80 바이트.  
2MB = 2만 6천장.

그림 출처:[http://www.maximumpc.com/files/u69/IBM\\_Punch\\_Card.png](http://www.maximumpc.com/files/u69/IBM_Punch_Card.png)

데이터는 무겁고  
컴퓨터는 비싸고



나는 1960년대에 예일 대학에 있었는데 그 때의 컴퓨터는 무척 크고, 비싸고 또한 몹시 귀했다. 그래서 전산 센터는 희귀한 자원이 있는 핵심 지점의 역할을 했다. 옛날 마을에서 공동 우물과 같은 역할인 셈이다. 컴퓨터를 이용해야 하는 입장이라면 그 무거운 펀치 카드 박스를 들고 멀리 걸어 다니고 싶진 않았을 것이다. (Mitchell, 2005)

그림 출처:<http://www.computescotland.com/images/EfVIPmeK4Y2B6oYEnMI10e30b7.jpg>



존 매카시(1961) 컴퓨터는 빠르  
니 여러 사람이 동시에 쓸 수  
있고 이걸 계속 발전시키면 컴  
퓨터 서비스가 물이나 전기와  
같은 서비스가 될 것이다.







릭라이더(1962) 전 세계 어디서나 원하는 프로그램과 자료를 활용할 수 있게 해주는 은하 네트워크 제안

SAGE(1950s) 컴퓨터 기반의 항공 방위 시스템용 사용자 단말

통신의 선구자



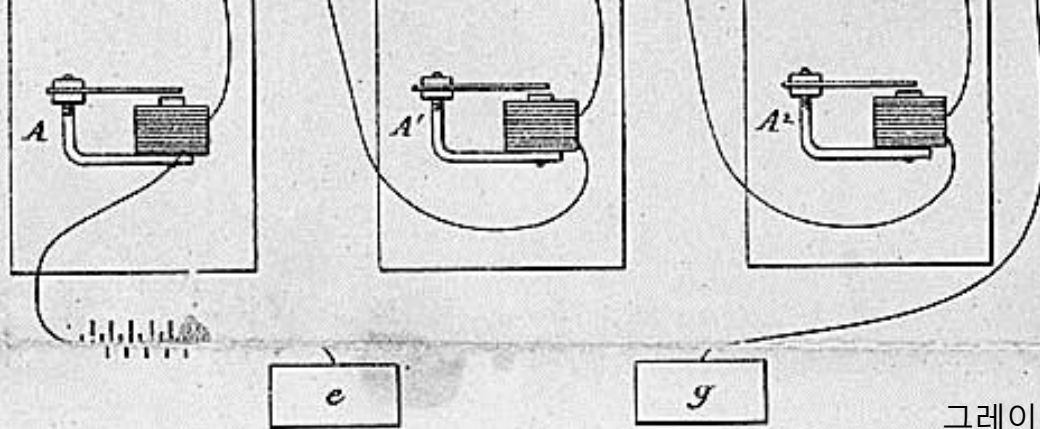

그레이엄 벨(1876)  
전화 특허 등록

Fig. 7

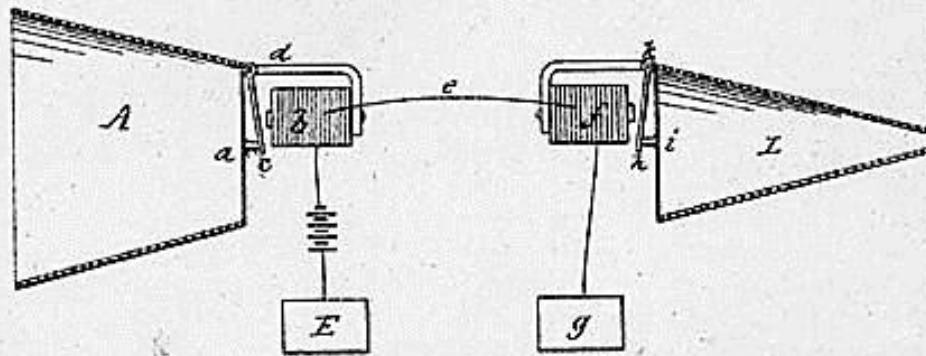

Witnesses

*E. W. Lippitt*  
*H. J. Hutchinson*

Inventor:

*a. Graham Bell*  
*by atty. Fuller Bailey*

*Telephone Patent*

**The Detroit News Timely Topics**



**Bell's First Telephone**

UNDERWOOD & UNDERWOOD, INC.  
WASHINGTON

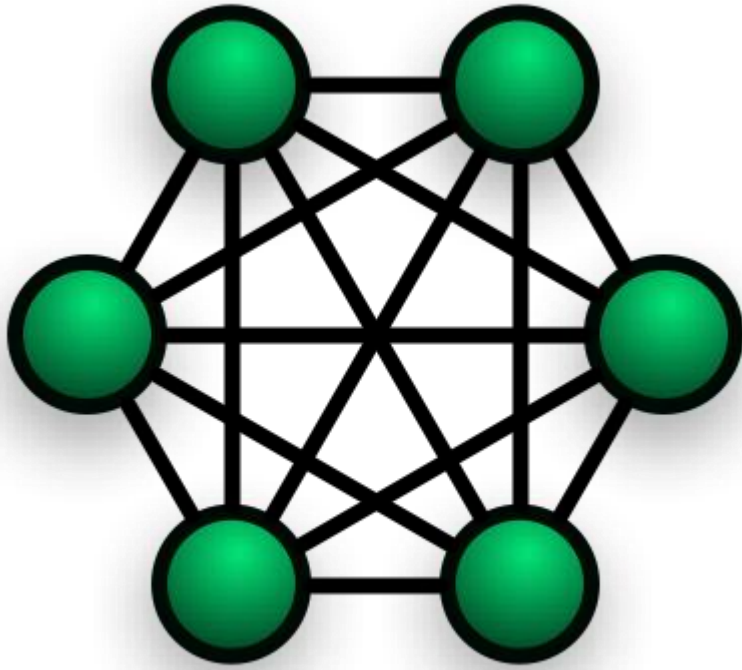

100억대의 컴퓨터를 완전히 연결하려면?

굵기 0.1mm의 회선으로 연결해도  
8만 Km 높이로 전 지구를 덮어야 한다.

$$n(n-1)/2 =$$

$$O(n^2)$$

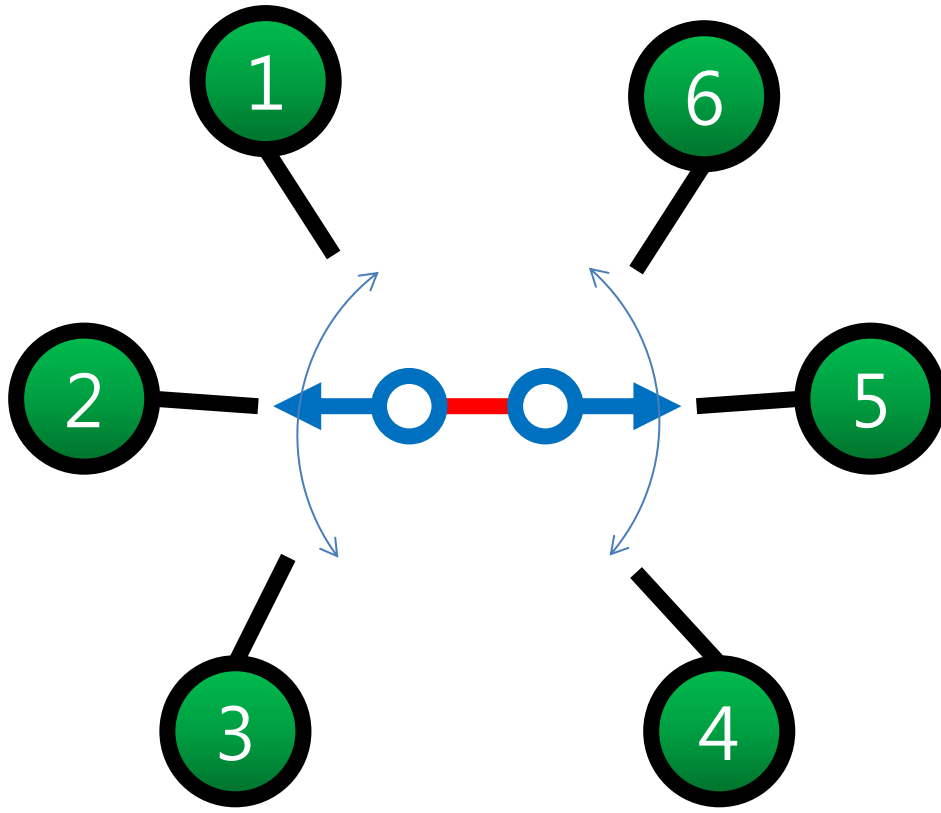

$$n+1 = O(n)$$

○—○의 갯수가 동시 통화 수를 결정

➔ 는 누가하지?



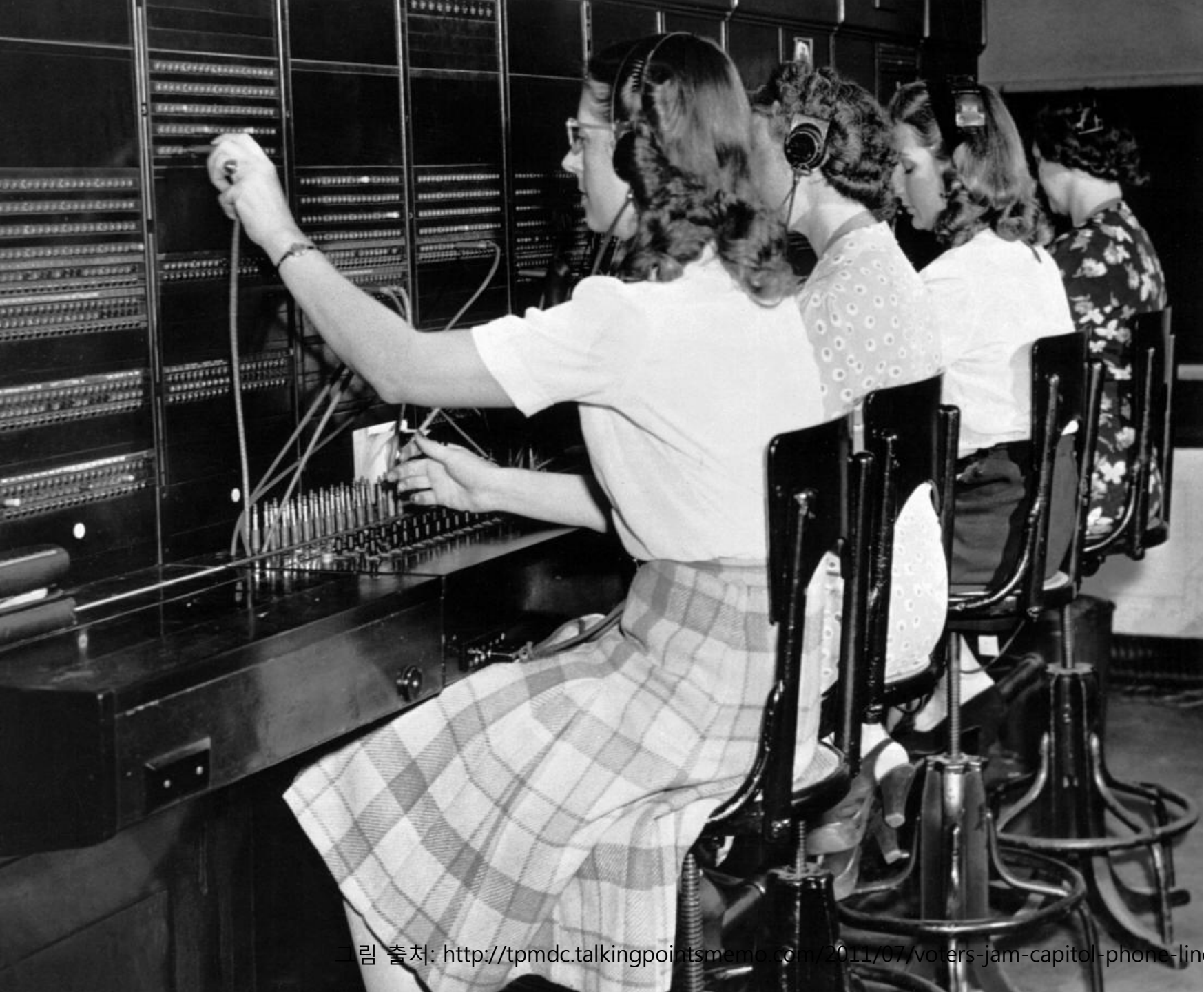

붙어야  
통한다

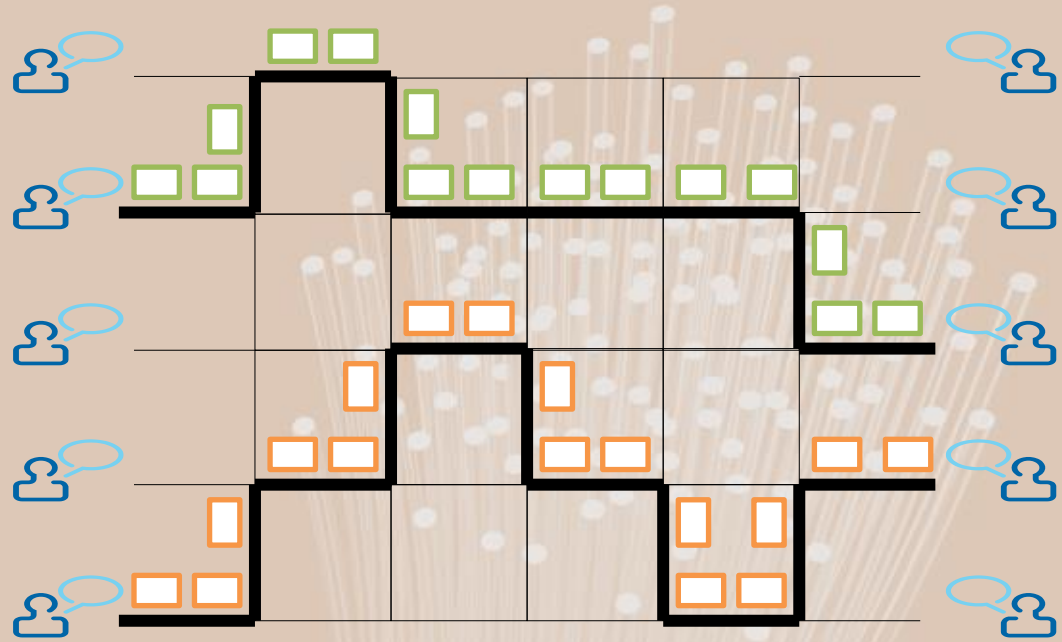

# circuit switching

길을 미리 뚫어 놓는다.  
 통화(세션) 끝까지 **전용**이다.  
 회선이 낭비될 수 있다.  
**품질**이 보장된다.  
 끊기면 **끊긴다**.

# 패킷의 탄생

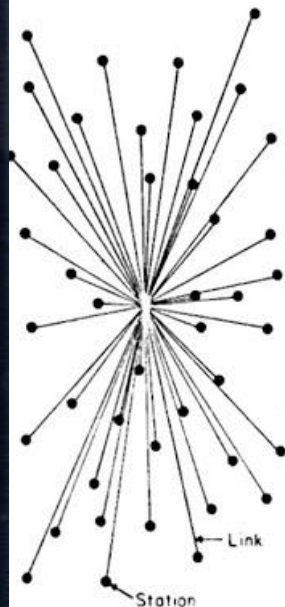

CENTRALIZED  
(A)

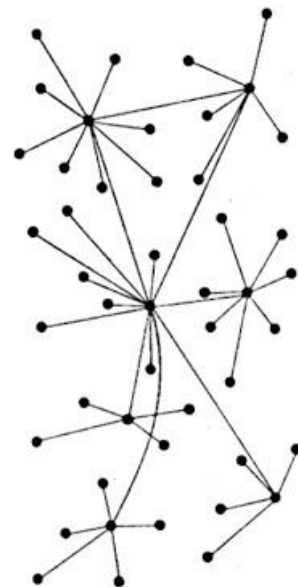

DECENTRALIZED  
(B)

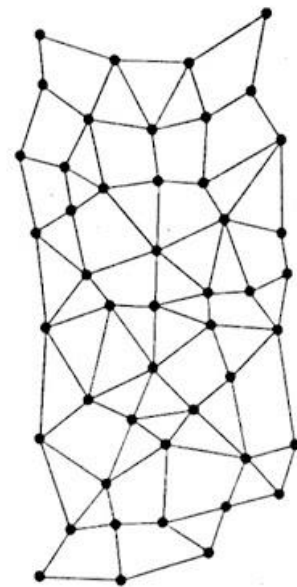

DISTRIBUTED  
(C)

레너드 클라인락 (1962)  
컴퓨터를 시간의 축으로  
쪼개서 공유할 수 있다면  
회선도 같이 하면 안돼?

폴 바란@RAND(1960)  
핵 무기에도 버티는  
생존형 통신 수단 개발

도널드 데이비스@NPL  
(1964) **패킷** 스위칭!



길을 미리 뚫어 놓는다.  
 통화(세션) 끝까지 **전용**이다.  
 회선이 낭비될 수 있다.  
**품질**이 보장된다.  
 끊기면 **끊긴다**.

# circuit switching

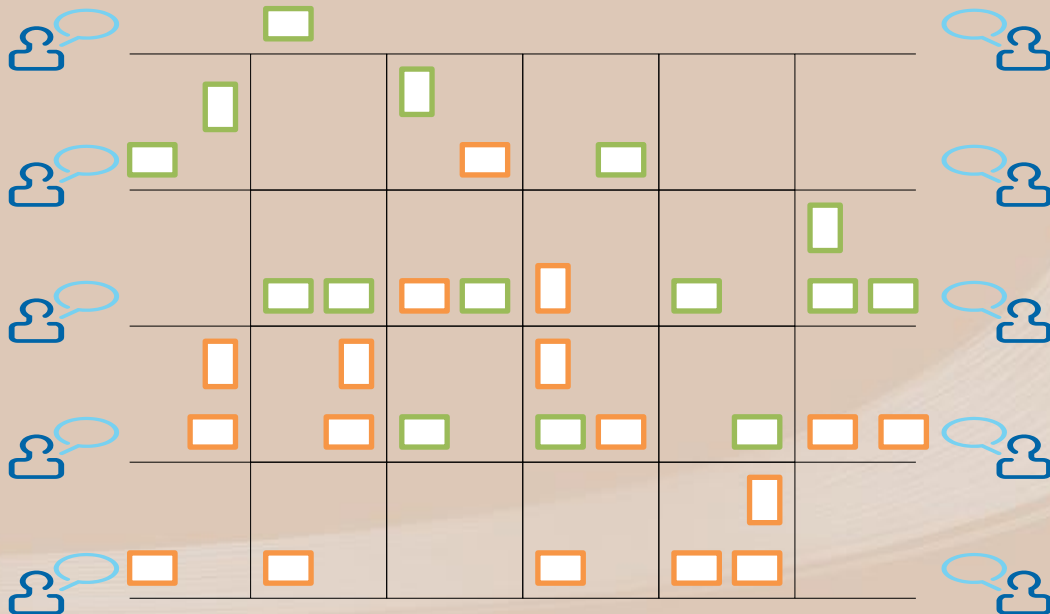
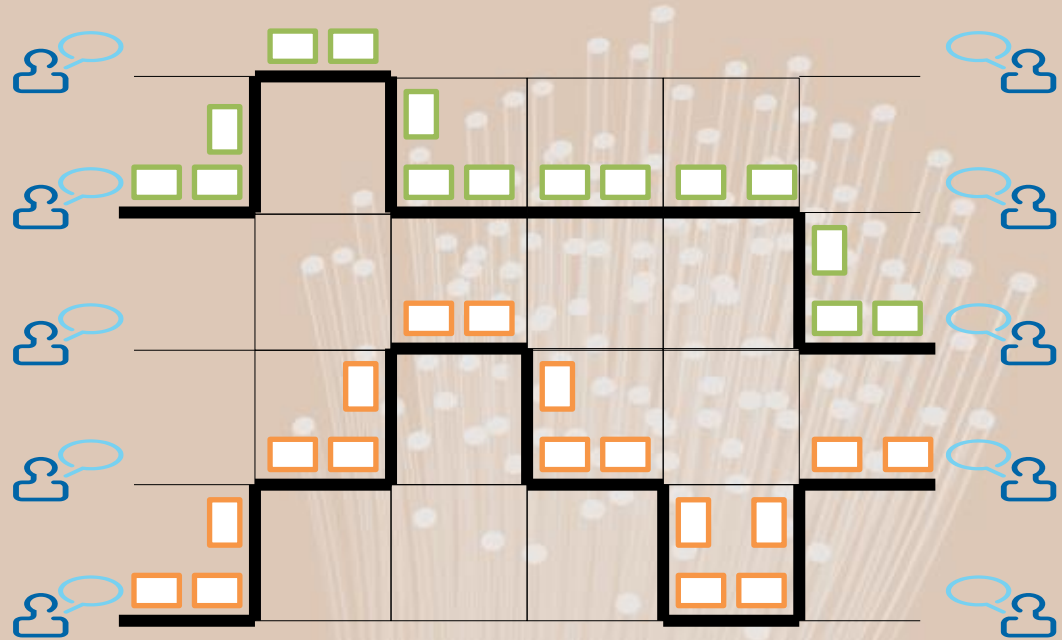

# packet switching

패킷을 전달할 때 길을 정한다.  
 통화(세션) 개념이 없다.  
 회선을 **공유**할 수 있다.  
 품질이 보장되기 가 거의 불가능.  
 끊기면 **돌아서라도 간다**.



패킷 덕분에  
회선의 독점 할당에서 해방되어

버스가 탄생

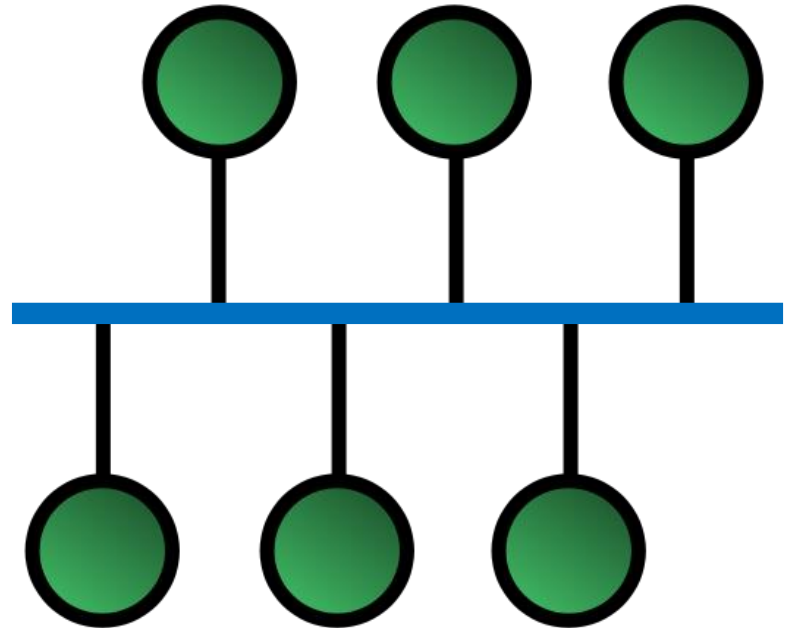



그림 출처: [http://farm8.staticflickr.com/7267/7113714943\\_902f956c5b\\_z.jpg](http://farm8.staticflickr.com/7267/7113714943_902f956c5b_z.jpg)  
costermk



그림 출처: <http://hbernstaedt.de/thinethernet.jpg>

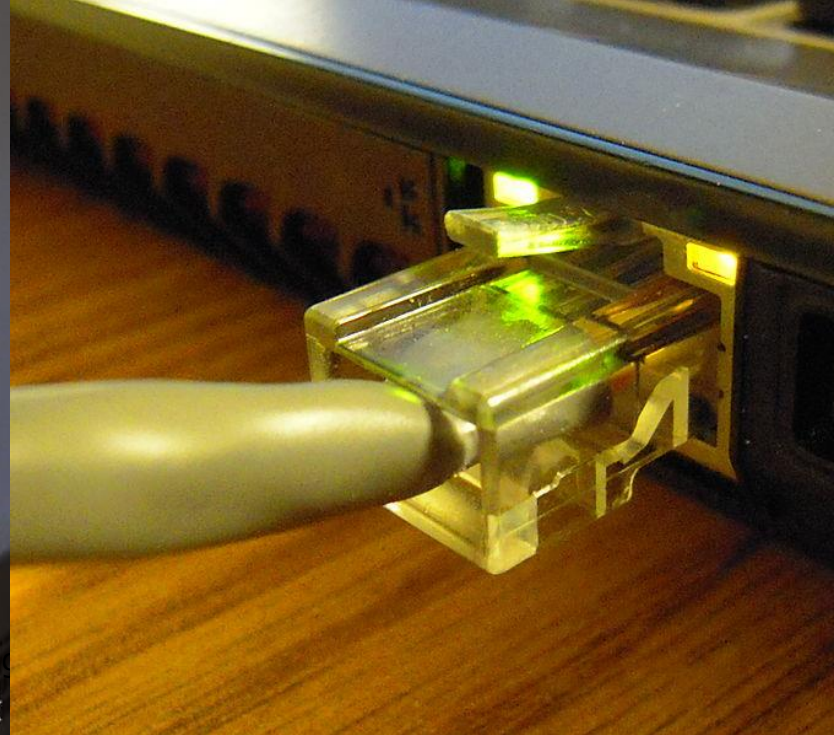

버스+패킷의 운명: 주소 & 충돌 →

→ 메트칼프(1973) Ethernet

MAC 주소를 봉투에

CS: carrier sense 남이 안 보낼 때

MA: multiple access 여럿이 공유

CD: collision detection 충돌 확인

→ **random** back off

→ 그리고 도청

Promiscuous mode

들리지만 못 듣는 척

기원전 3세기의 아리스토텔레스는 우주의 중심이 지구이고 그 위로 달, 태양, 행성이 수정 구면 위에 붙어 궤도를 돌고 있다고 주장했다. 세계는 (무거운 순서로) 흙, 물, 공기, 불의 4원소로 구성되어 있어 불완전하(고 땅으로 추락하)지만 우주의 천체는 **완벽한 물질인 에테르**로 구성되어 있어 완벽하(고 땅으로 추락하지도 않는)다고 했다. 이런 생각은 16세기까지 유럽에서 받아들여졌다. (nasa 홈페이지에서 발췌 번역)

그림 출처: <http://elementsunearthed.com/2009/06/>



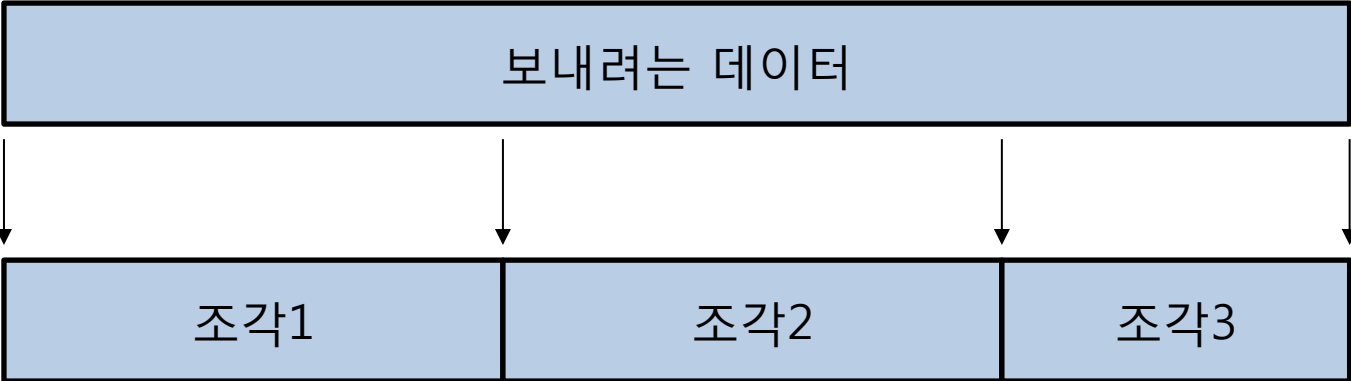

MAC 패킷

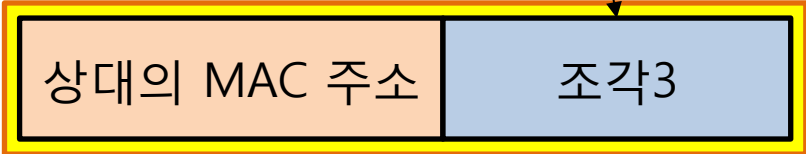
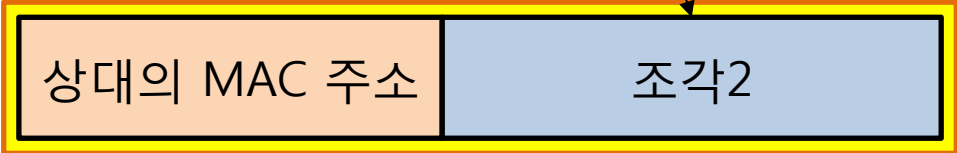
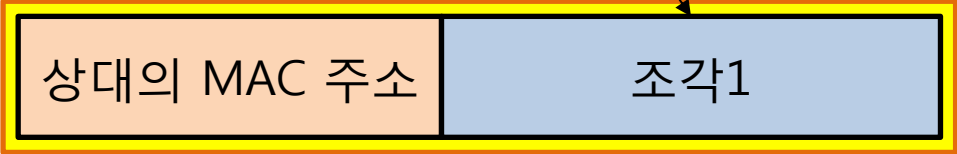



# MAC or L2

직접 연결된 컴퓨터  
끼리 데이터를  
주고 받을 수  
있게 되었다

# 전 지구 단일 버스 네트워크

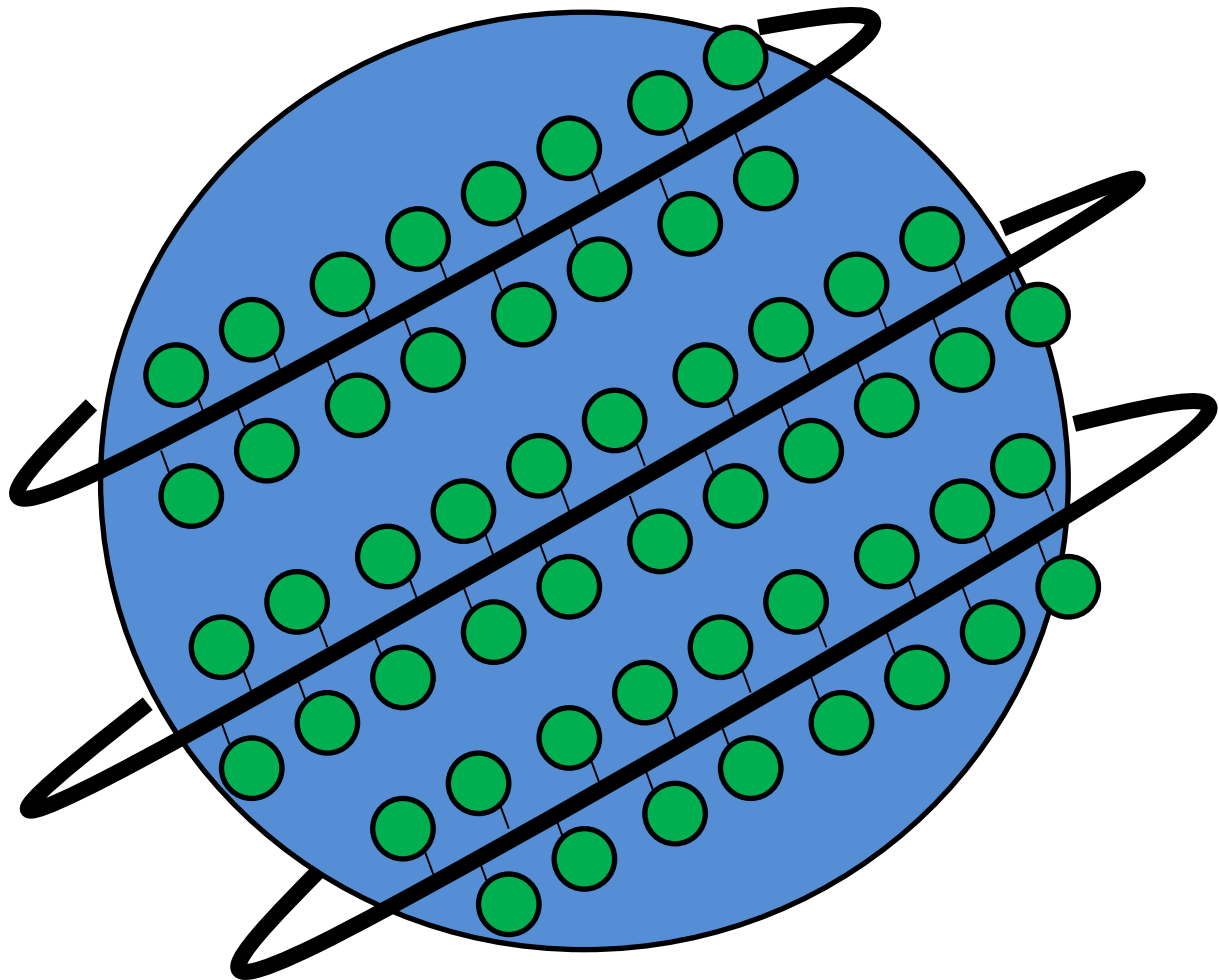

곰벵이 빛 또는 너무 큰 지구



하나로 안 된다 → 여러 네트워크로 쪼개자.  
서로 연결은? → 양 다리 걸친 장비를 만들자.

### 게이트웨이의 고민

- 무엇을 퍼 나를지 어떻게 아는가?
- 그것을 알기 위한 비용을 어떻게 줄일 것인가?

# inter - net

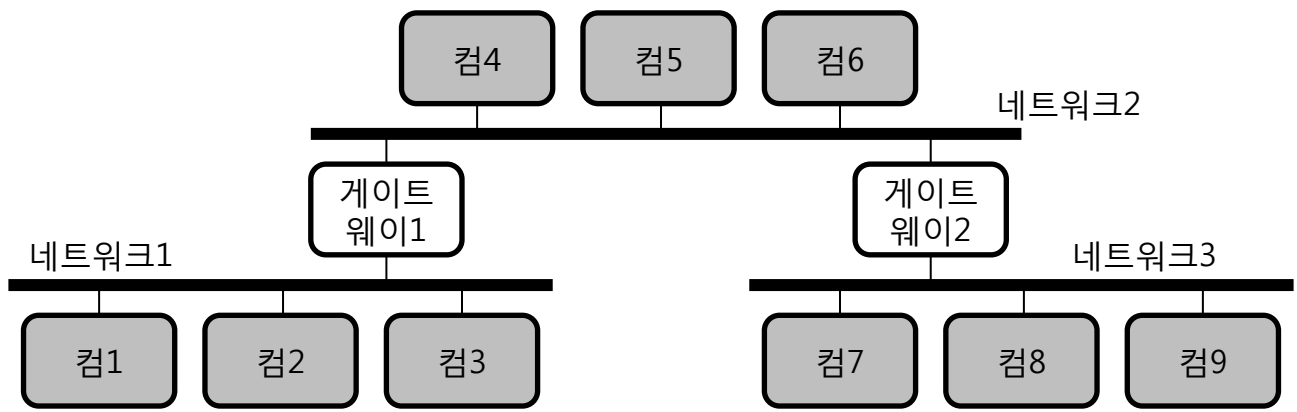



프레데릭 스미스 (1960s)  
대학 리포트로 IT 기술을  
이용한 당일 배송 시스템  
제안 → C학점  $\pi\pi$

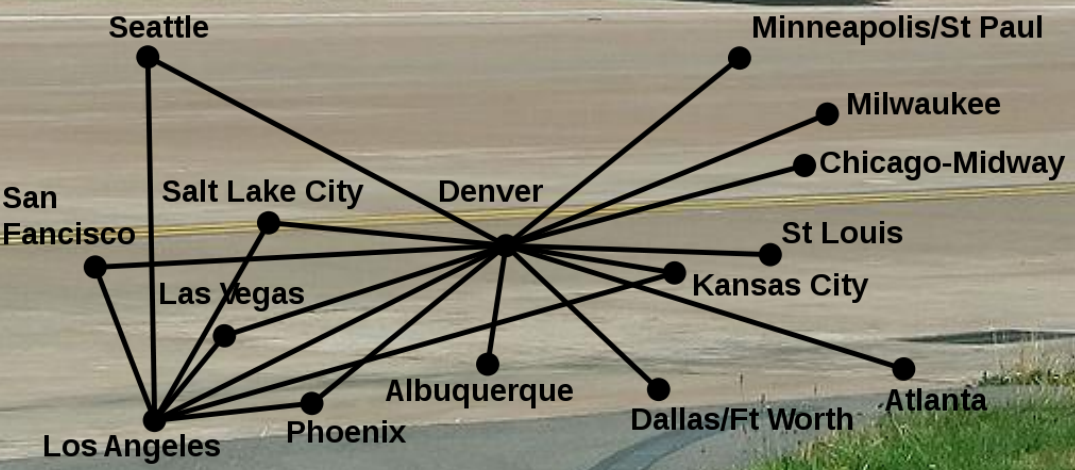

1. 모르면 위로 보내라. 고민은 한 곳에서 하자.
2. 주소는 "위치"를 나타내야 한다. (!= MAC)  
 → 컴퓨터 주소 = 네트워크 주소 + 자신을 구별하는 번호  
 ~ = "서울시 종로구 세종로" + "1번지"

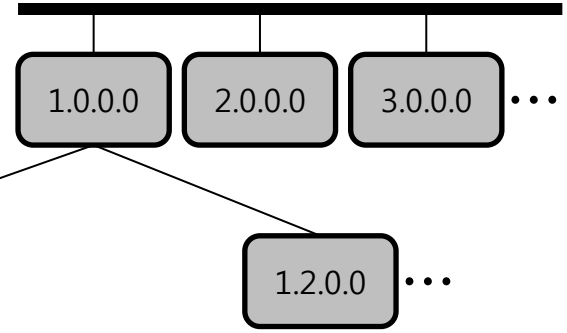
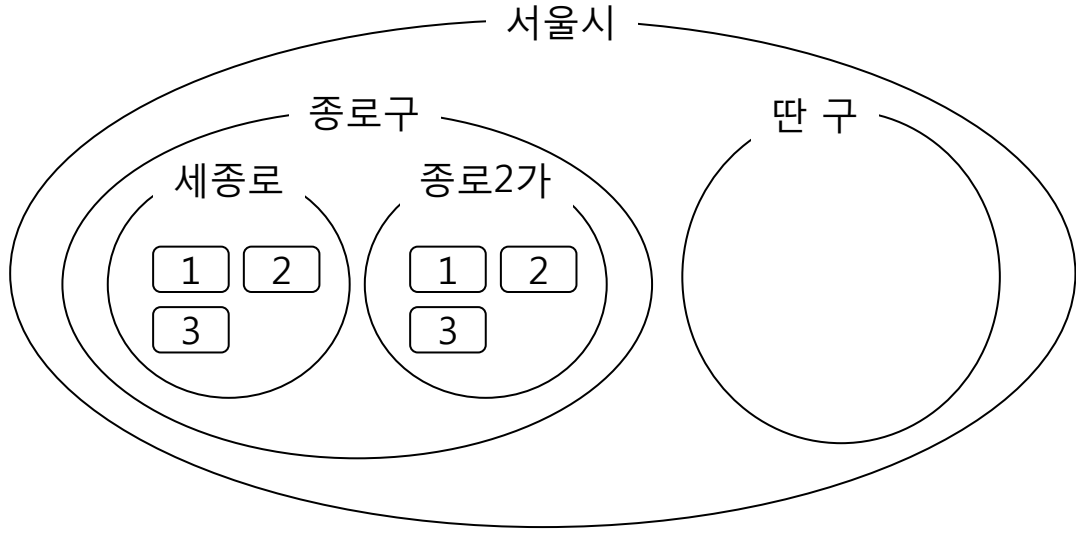
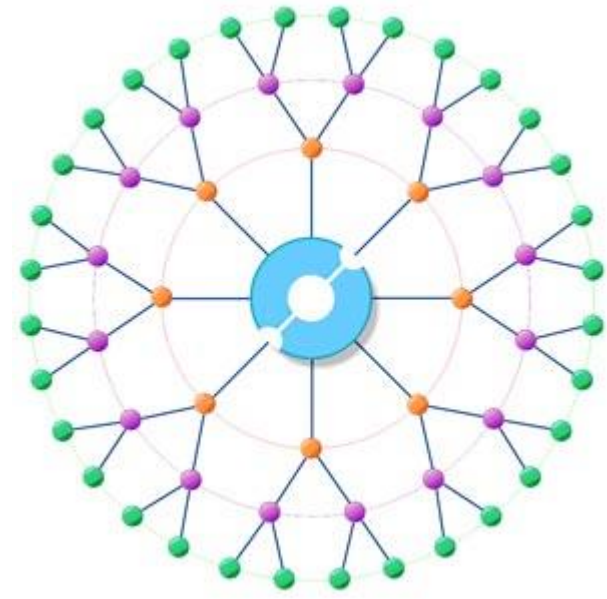

1.1.1로 시작하면 왼쪽  
 1.1.2로 시작하면 오른쪽  
 그 외는 위로 보낸다

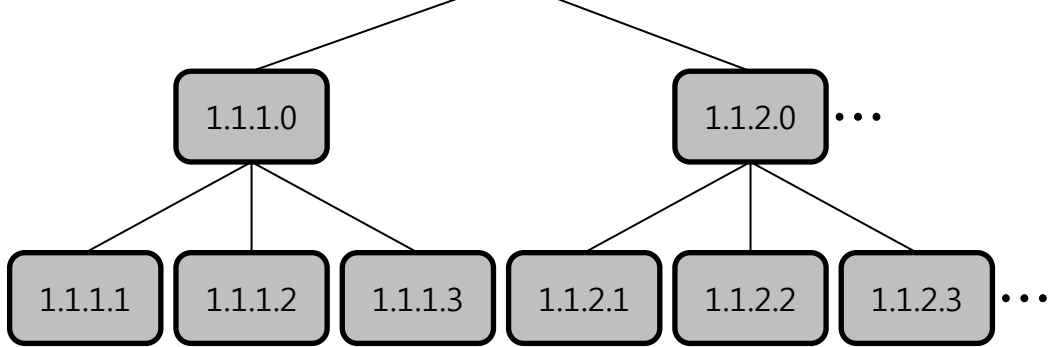

# IP 주소 & 라우팅

# IP or L3

전세계 컴퓨터가  
어디 있든 **찾아갈 수**  
있게 되었다



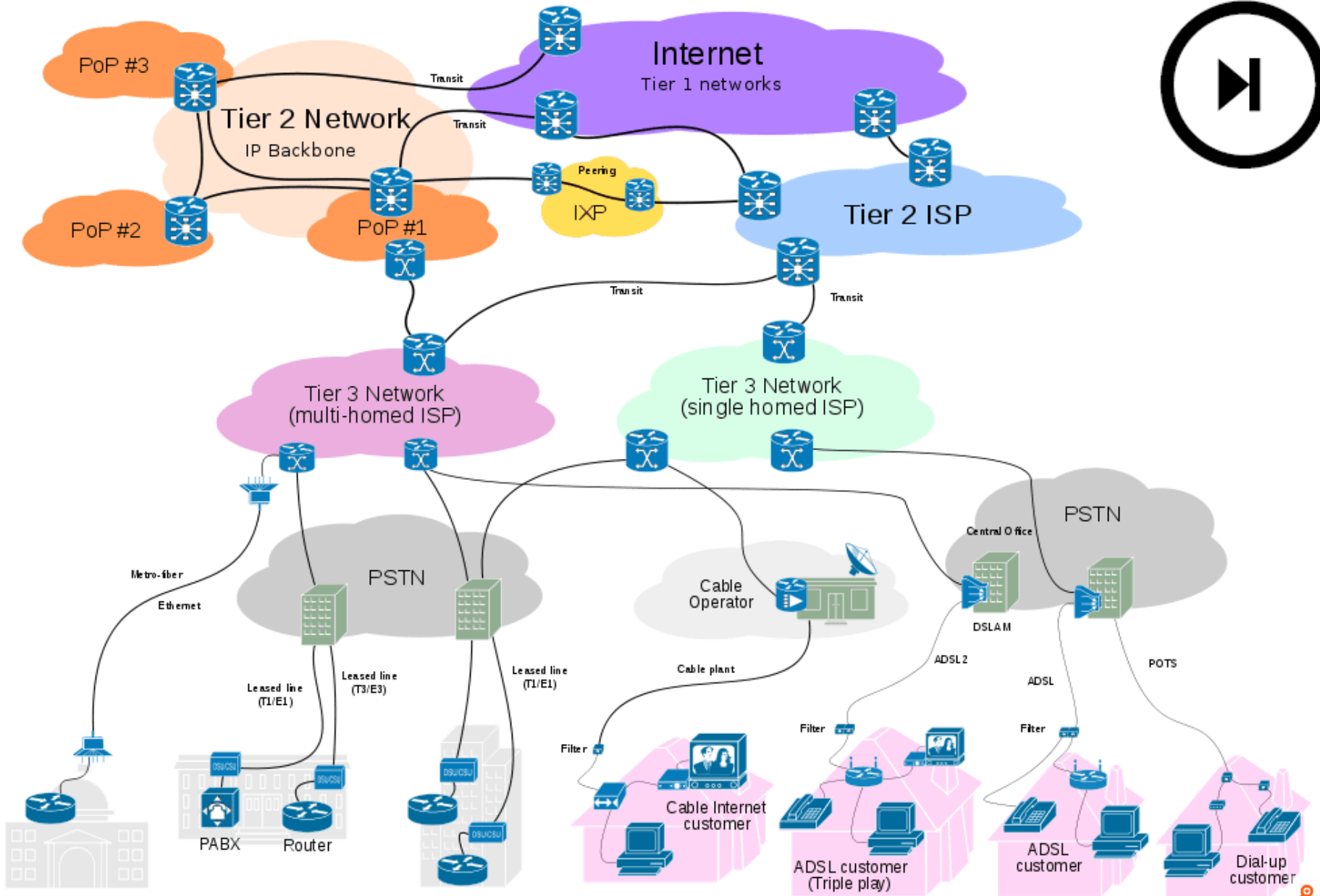

# CAIDA's IPv4 & IPv6 AS Core AS-level INTERNET Graph

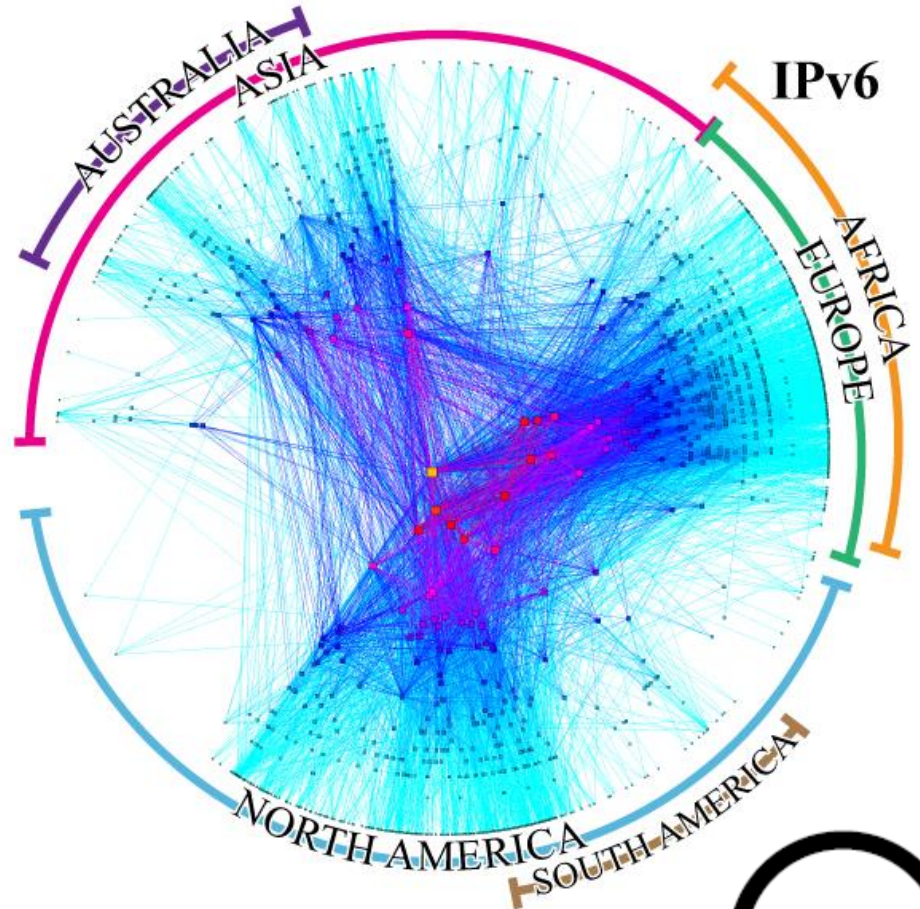
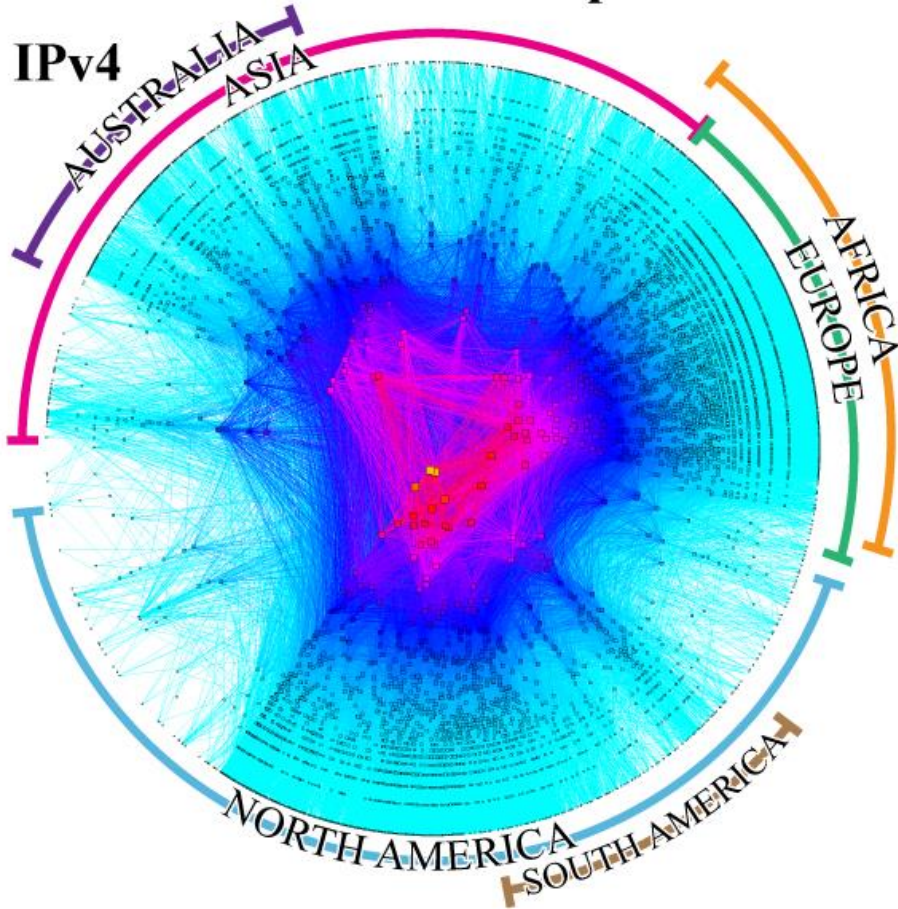

앞에서 안 하고 넘어온 이야기  
상대의 **MAC 주소**는 어떻게 알 수 있나?



내가 접속하려는 컴퓨터(의 네트워크 연결 장치)



전 세계 어디로든 연결  
하려면 **IP 주소**가 필요  
(IP 주소 = 위치 + ID)

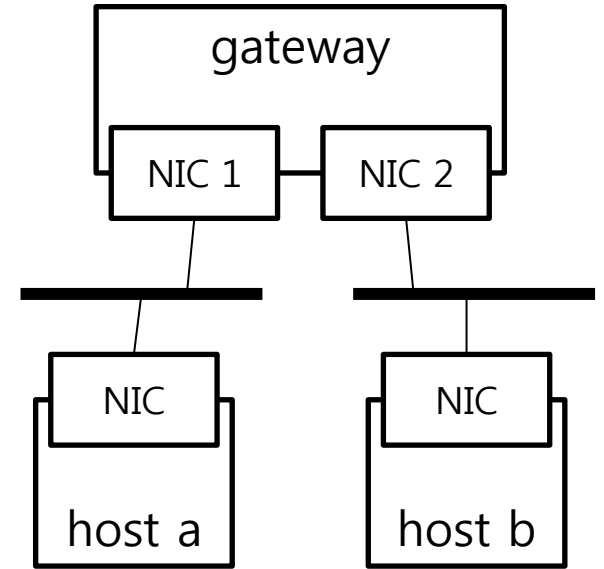
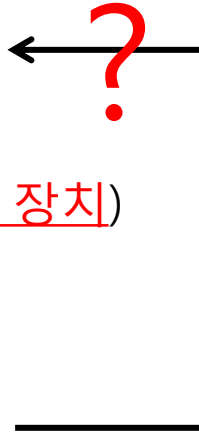

ARP 요청



ARP 응답



# ARP의 명과 암

- Man-in-the-middle attack
- Denial of service attack
- + IP 통제



Routing under normal operation



Routing subject to ARP cache poisoning

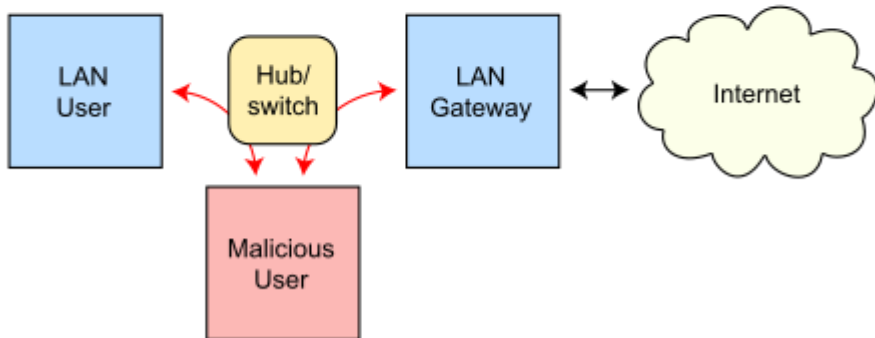



MAC 패킷

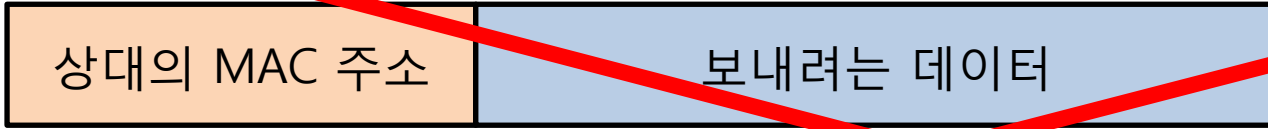

같은 버스에서만

IP 패킷



인터넷 전체

# 하지만...

패킷을 보내고 받는 양자는 **연결**되어 있어야 한다 → 항상 MAC 패킷으로 보내야

## MAC의 탈을 쓴 IP



IP 패킷이 생각하는 내용물

MAC 패킷이 생각하는 내용물 = IP 패킷



# + ARP

같은 네트워크에 연결된  
컴퓨터의 IP 주소를 알면  
MAC 주소를 안다

→ 데이터를 보낼 수 있다.

상대가 **같은 네트워크**면 그냥 데이터를 보내면 되고 **다른 네트워크**면 네트워크를 연결하는 컴퓨터 즉, **게이트웨이**에게 전달해달라고 부탁하면 된다.

같은지 다른지  
어떻게 알지?  
게이트웨이 주소는  
어떻게 알지?

아는 방법 **없다!**  
알려줄 수 밖에

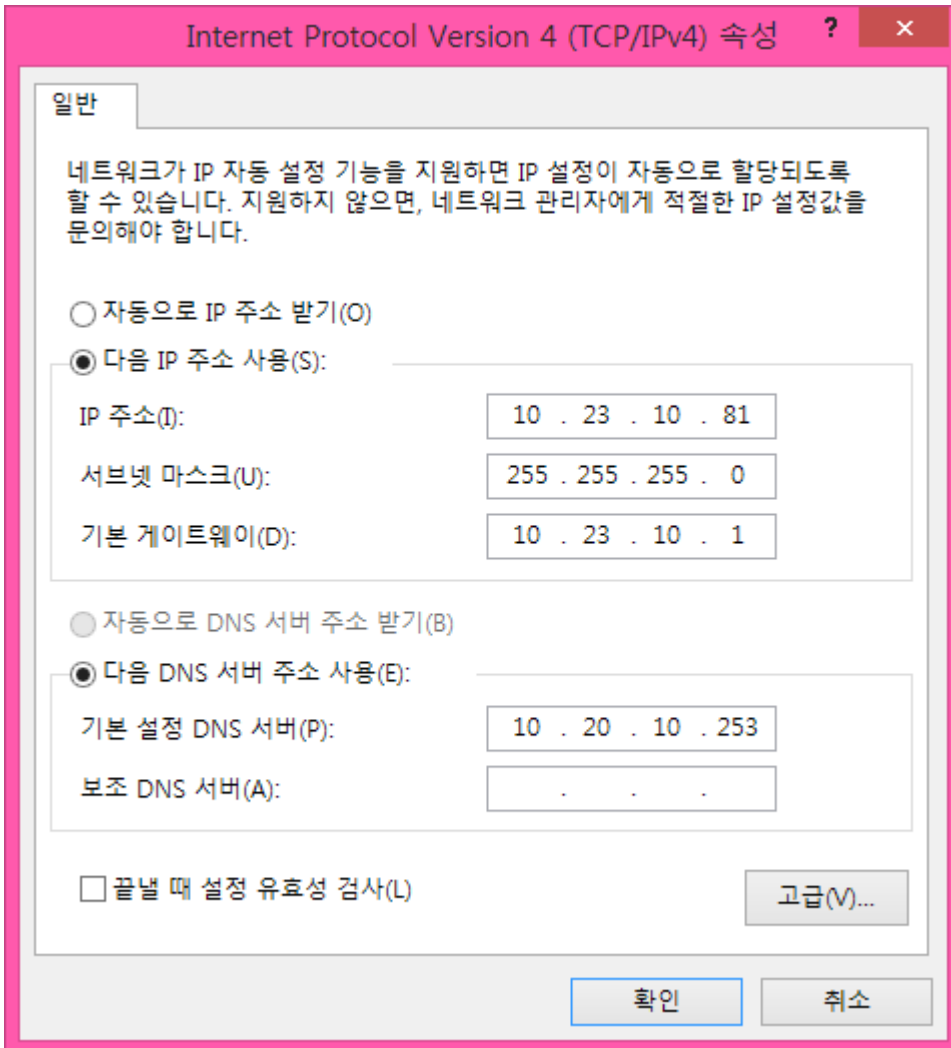

게이트웨이 1.1.1.0이 받은 패킷

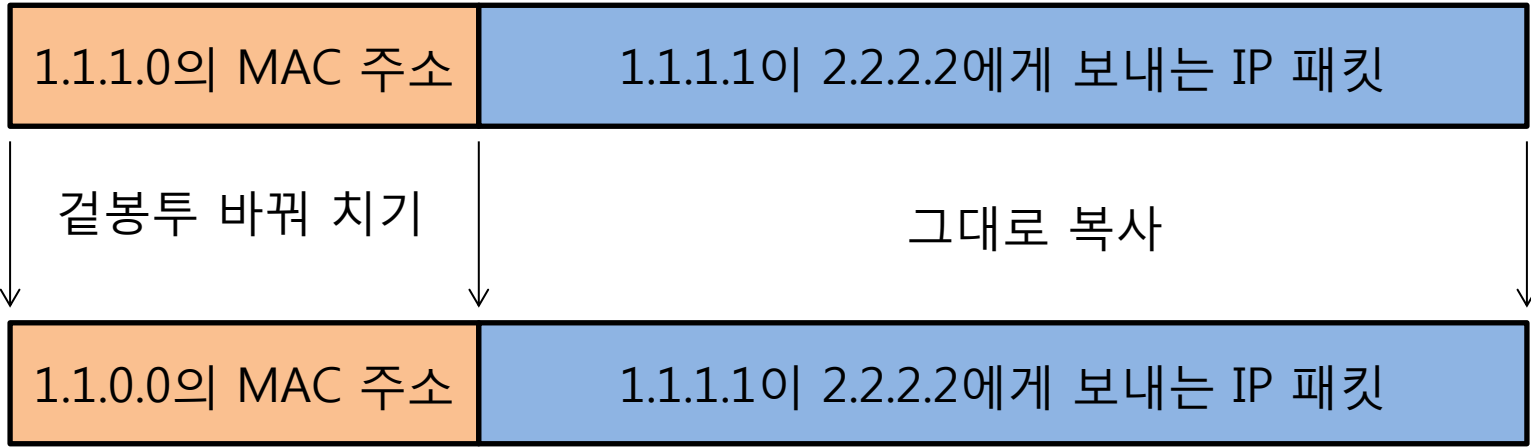

게이트웨이 1.1.0.0에게 떠넘긴 패킷

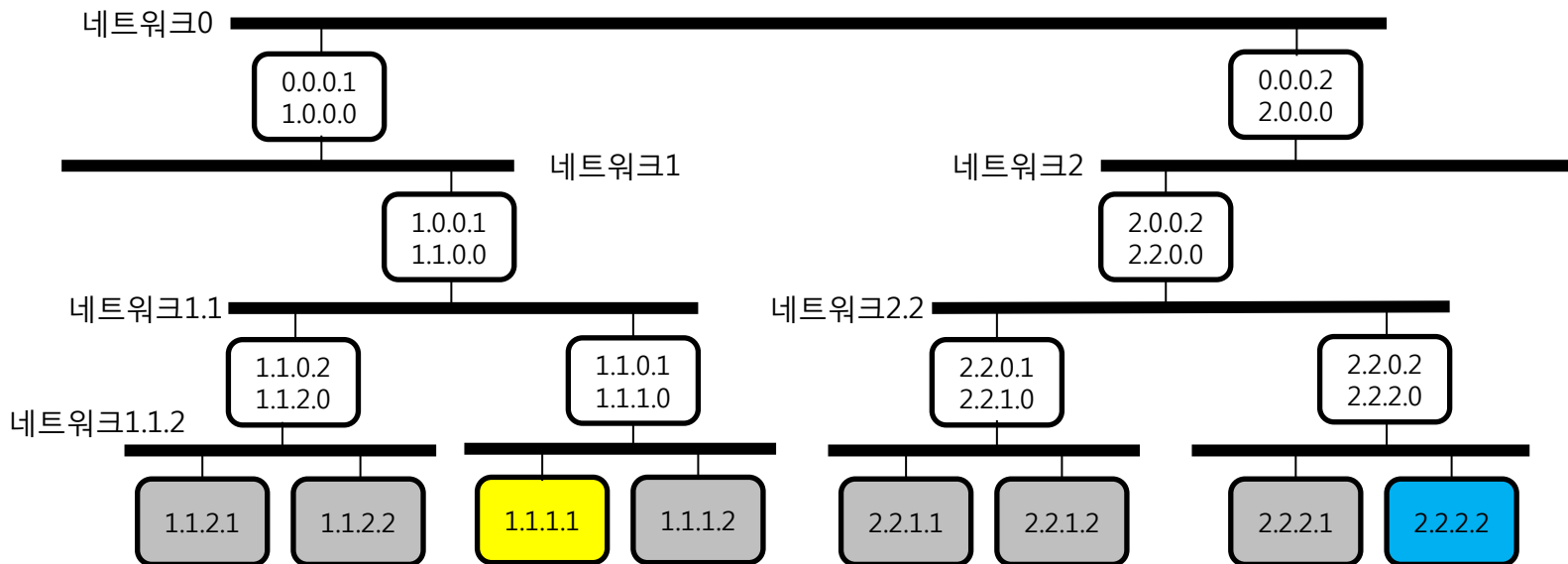

포  
대  
갈  
이



# L2 + L3

전세계 어느 컴퓨터로나  
상대의 IP 주소를 알면  
데이터를 보낼 수 있다.

# Data Flow

L4

L3

L2

L1

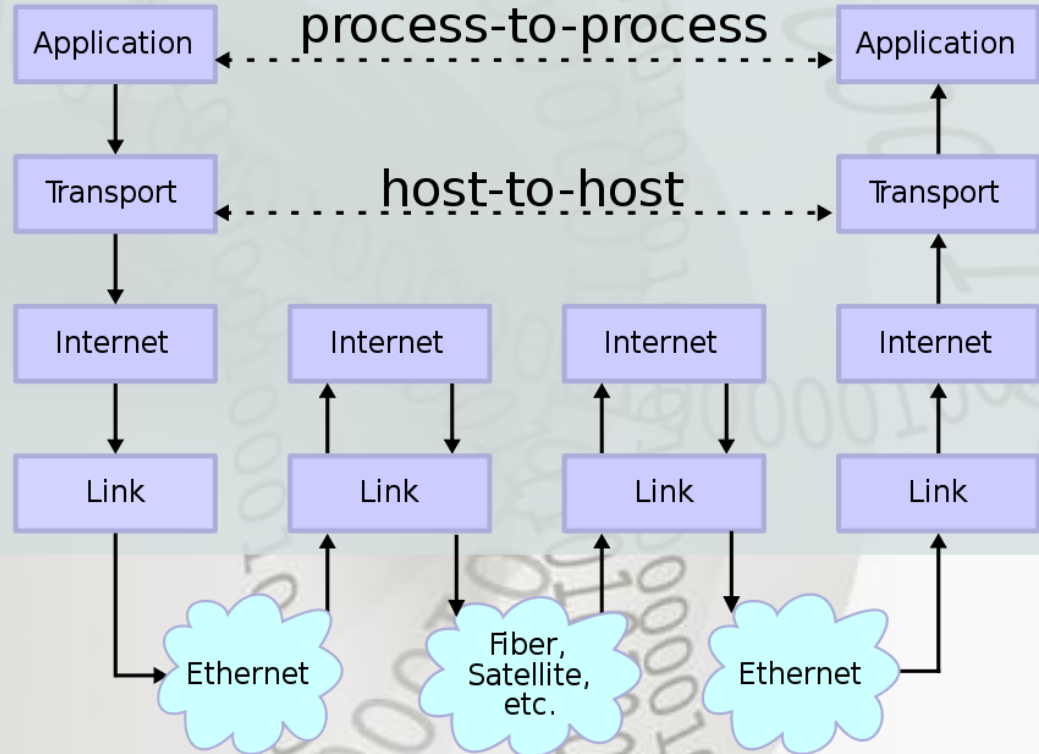

오르락 내리락



동네1 → 장비1 → 상위ISP1 → 상위ISP2 → 장비7 → 동네7  
동네1 → 장비1 → 장비2 → 장비3 → 장비5 → 장비8 → 장비7 → 동네7

가는 길은 네트워크 장비의 **설정**에 따른다.  
설정에는 이윤을 최대화하기 위한  
**여러 가지** 요소가 고려된다.

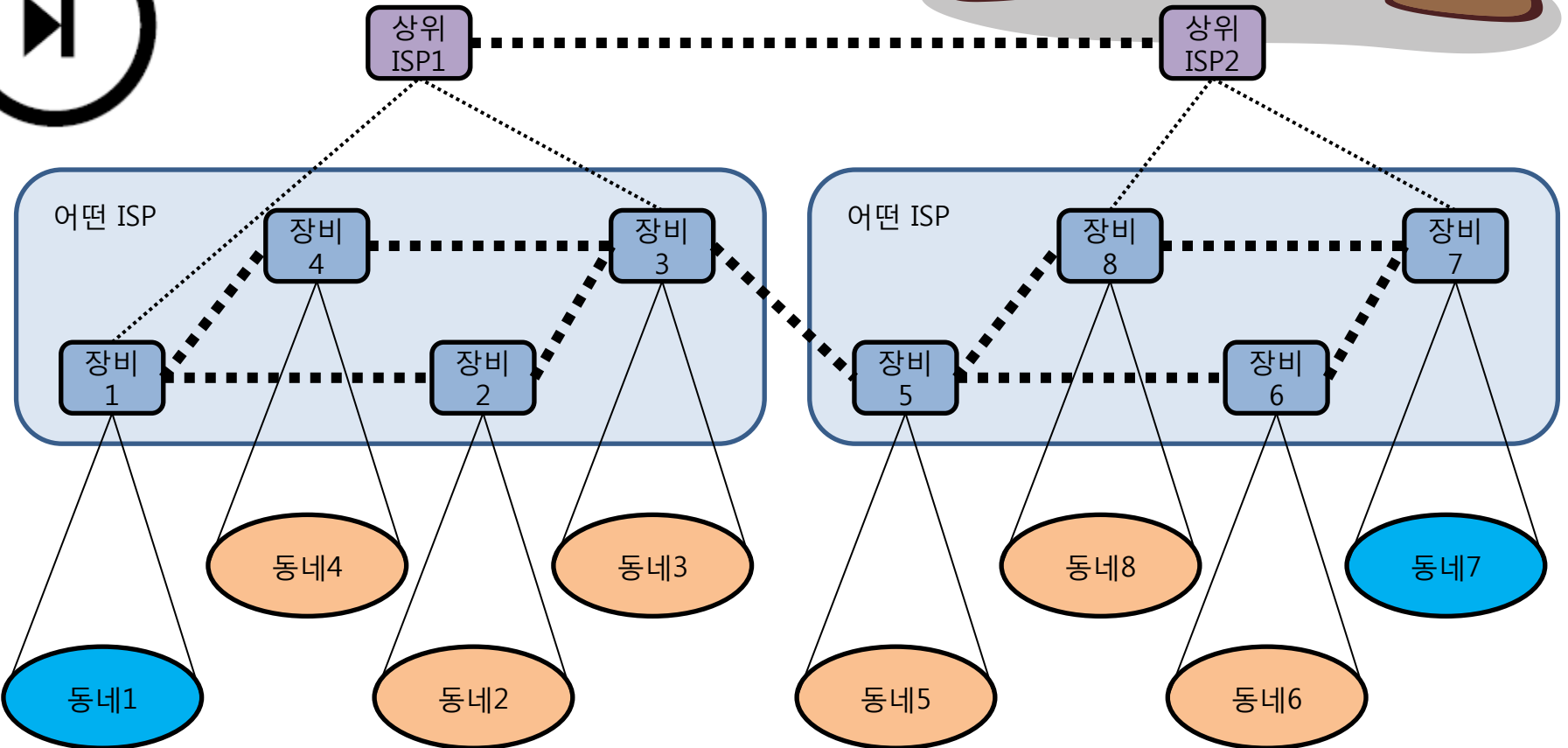
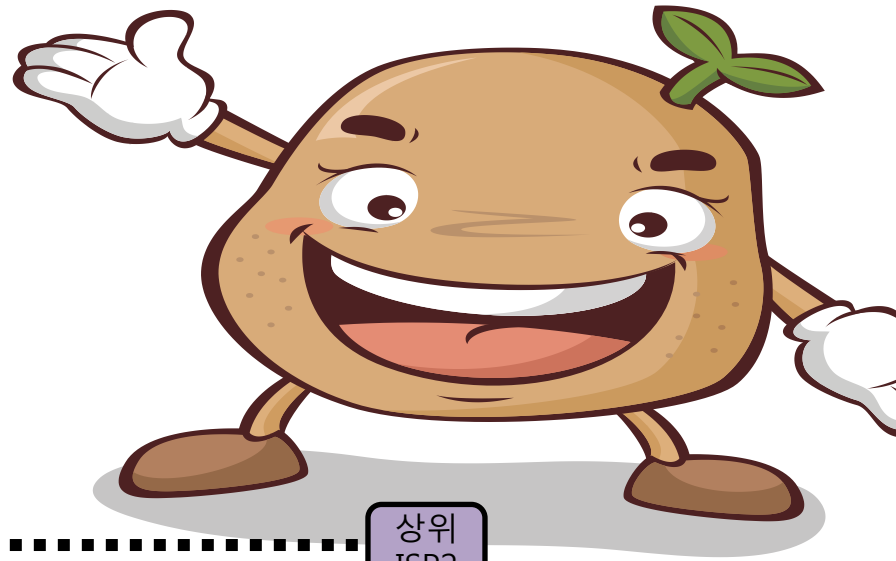

h G

빠름

빠름

빠름



패킷의 전달 속도는 **거의** 같다. 다만 길이 넓어질 뿐



# 굵고 짧게 혹은 가늘고 길게

패킷 몇 개 보내서는 樂이 없다.

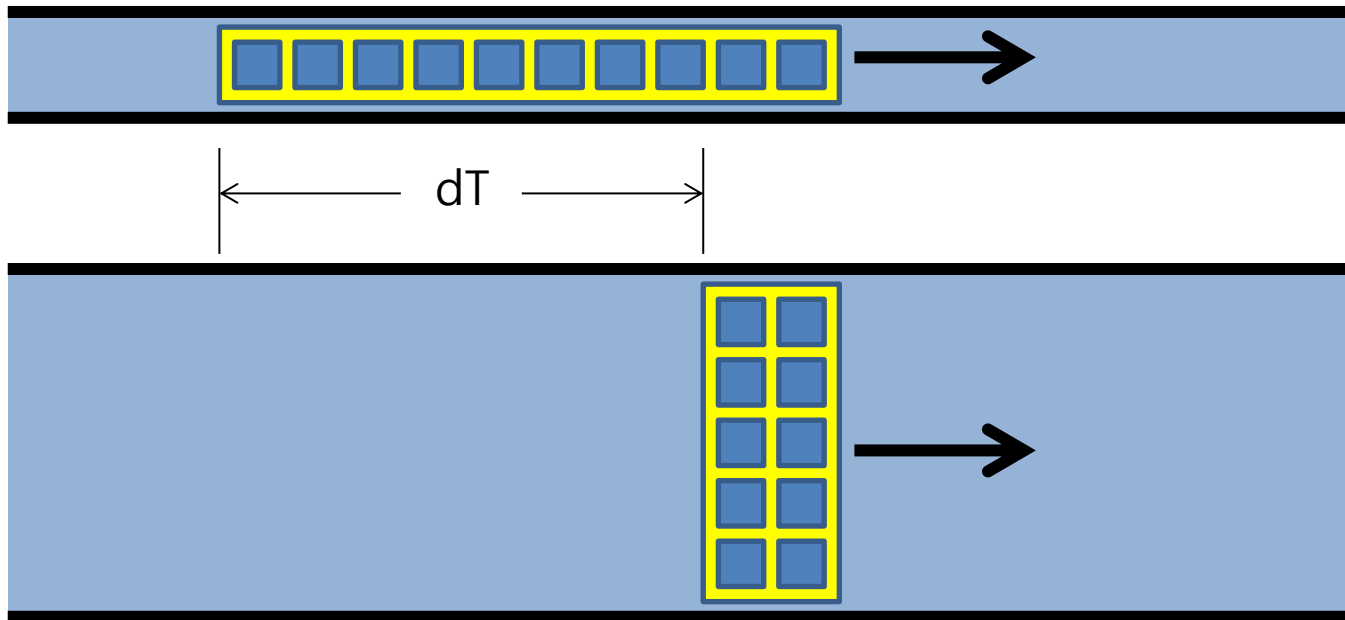

n개 연달아 보내면  $n \times dT$  만큼 짧아진다!

네트워크A

네트워크B

네트워크C

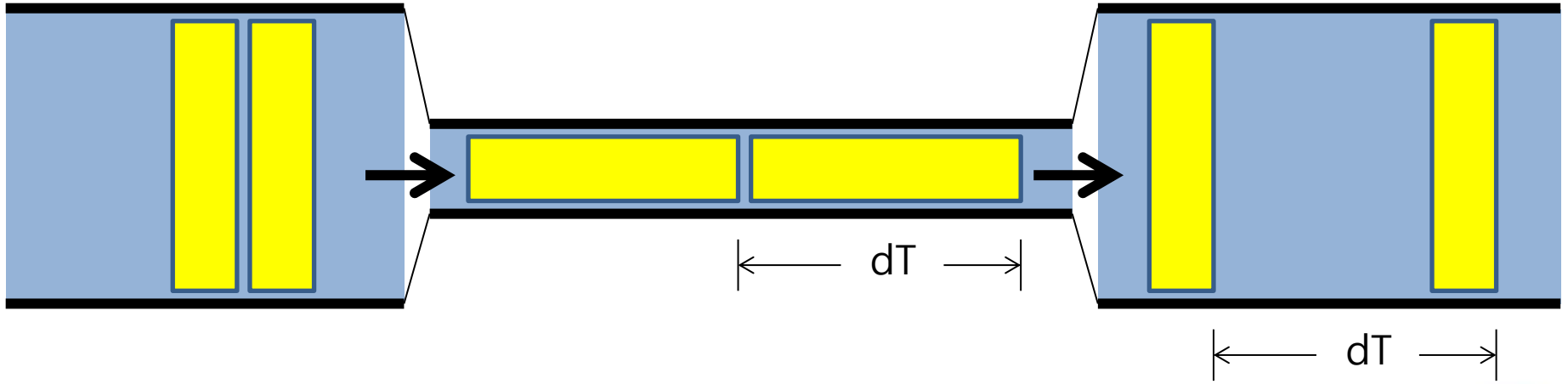

연달아 보낸 것이 무색하다.

그리고 패킷이 **손실** 될 수도...



## 순진한 ARQ

전달을 확인할 수 있지만 전달아 보낼 수 없다.  
패킷 손실을 확인하는데 오래 걸린다.

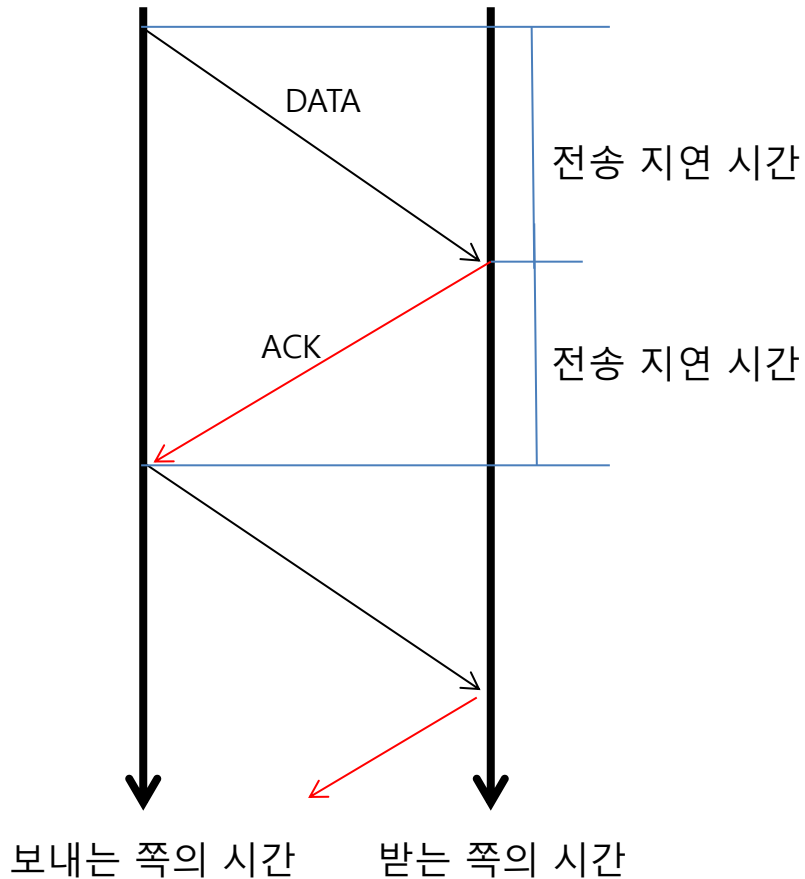

## 윈도 개념 적용

답이 안 와도 몇 개는 믿고 보내자.  
패킷 손실도 더 빨리 알 수 있다. 왜?

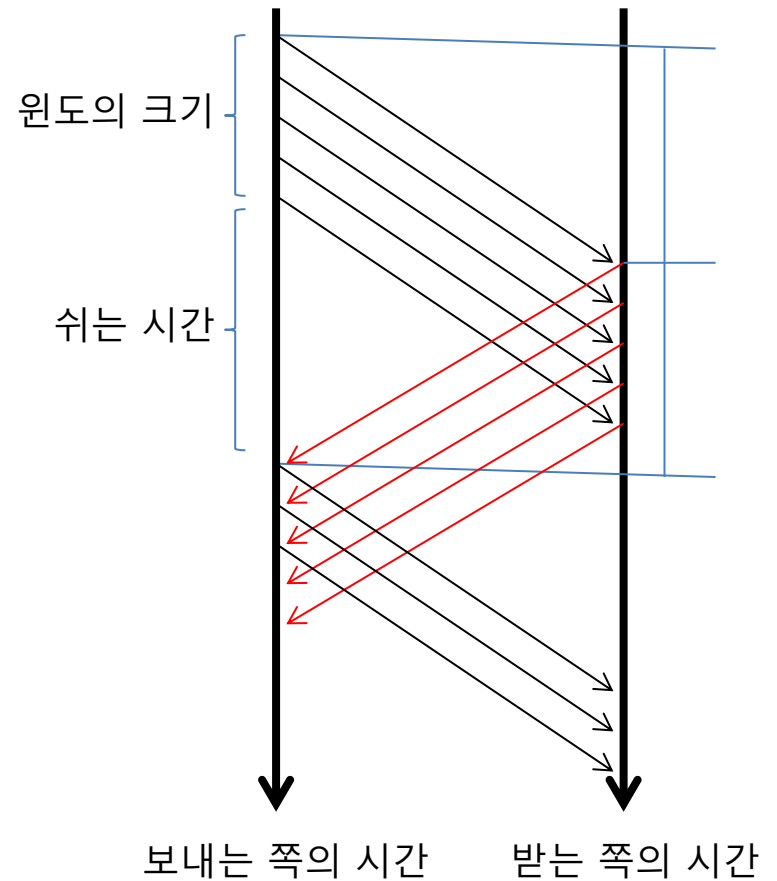

전송 계층 프로토콜의 목표는

# Bandwidth x Delay

만큼의 패킷을 네트워크에 흐르게 하는 것!

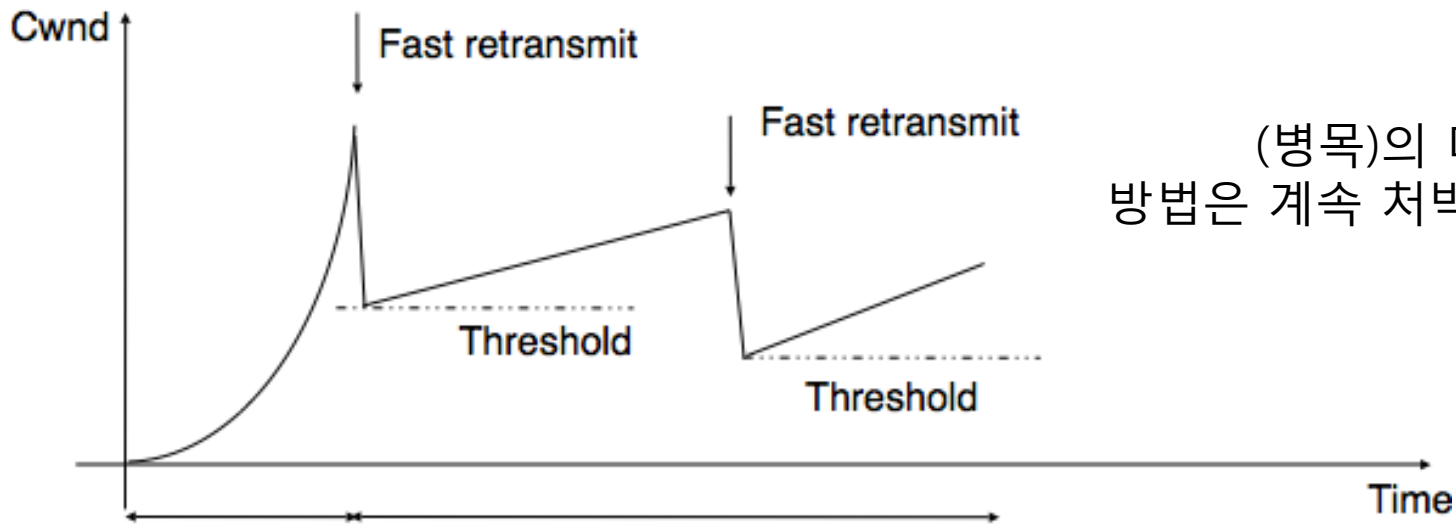
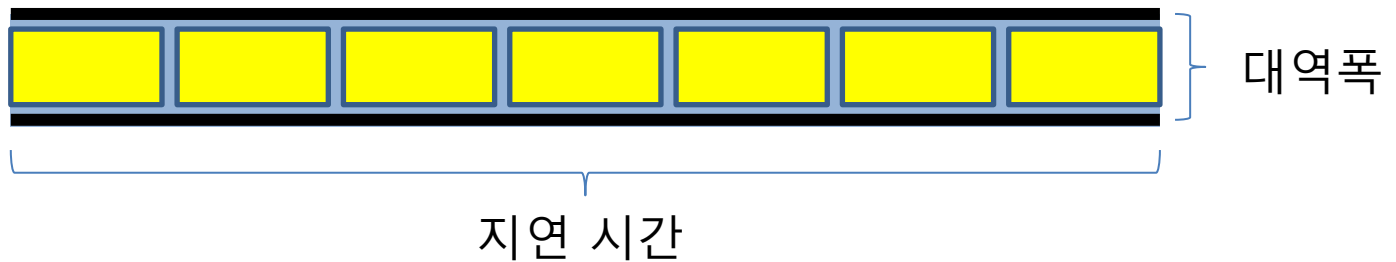

(병목)의 대역을 아는  
방법은 계속 쳐박는 수 밖에  
→ AIMD

**Slow-start**  
exponential increase of cwnd

**Congestion avoidance**  
linear increase of cwnd



# TCP or L4

전세계 어느 컴퓨터로나  
데이터를 **빨리** 그리고  
**깨지지 않게** 보낼 수 있다.

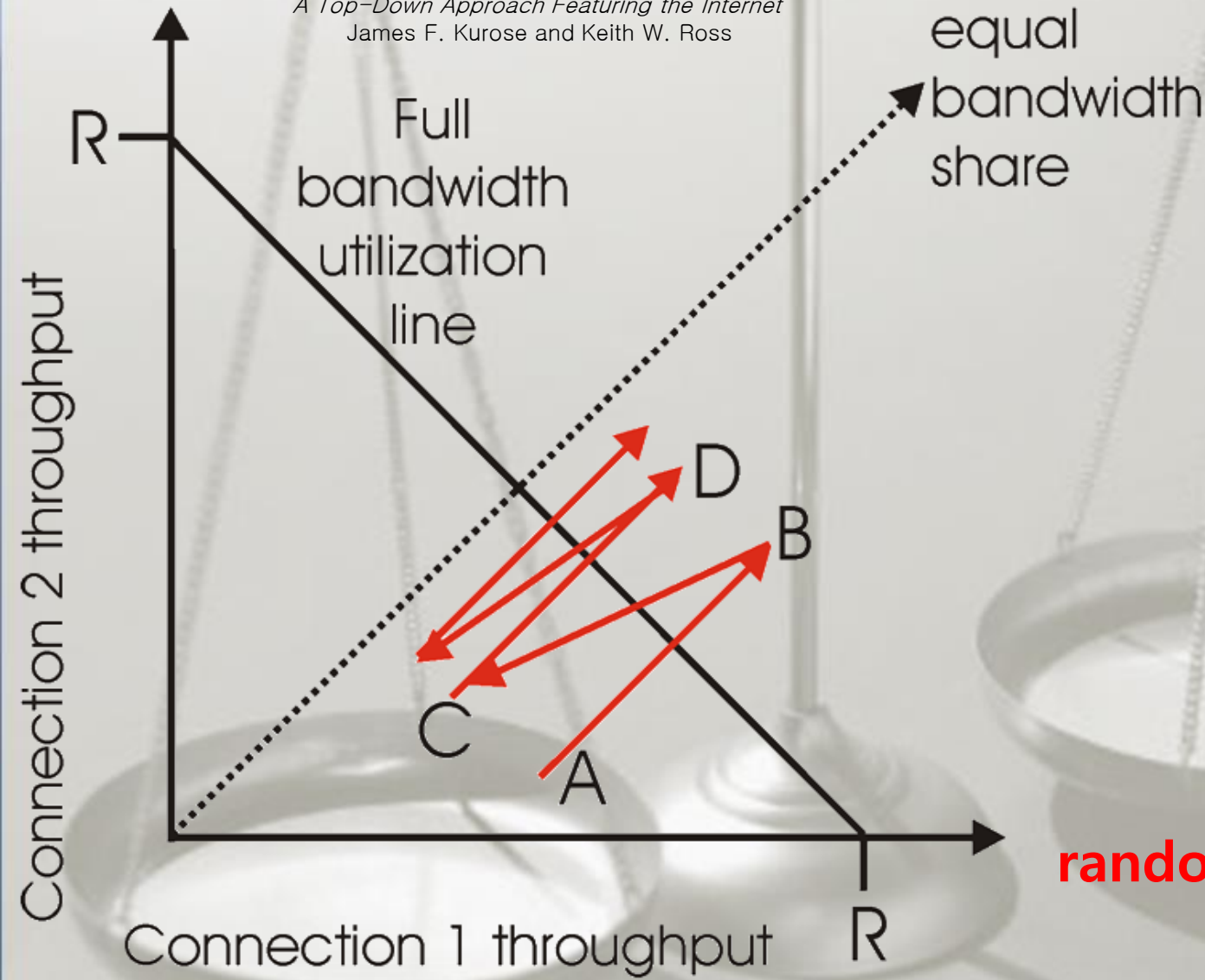
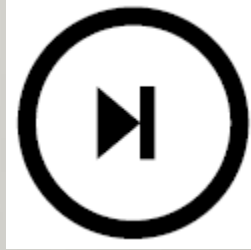

tail drop vs.  
**random early drop** vs.  
any others

네트워크에서의 **의도적 간섭**은  
언제 얼마나 허용되어야 하는가?

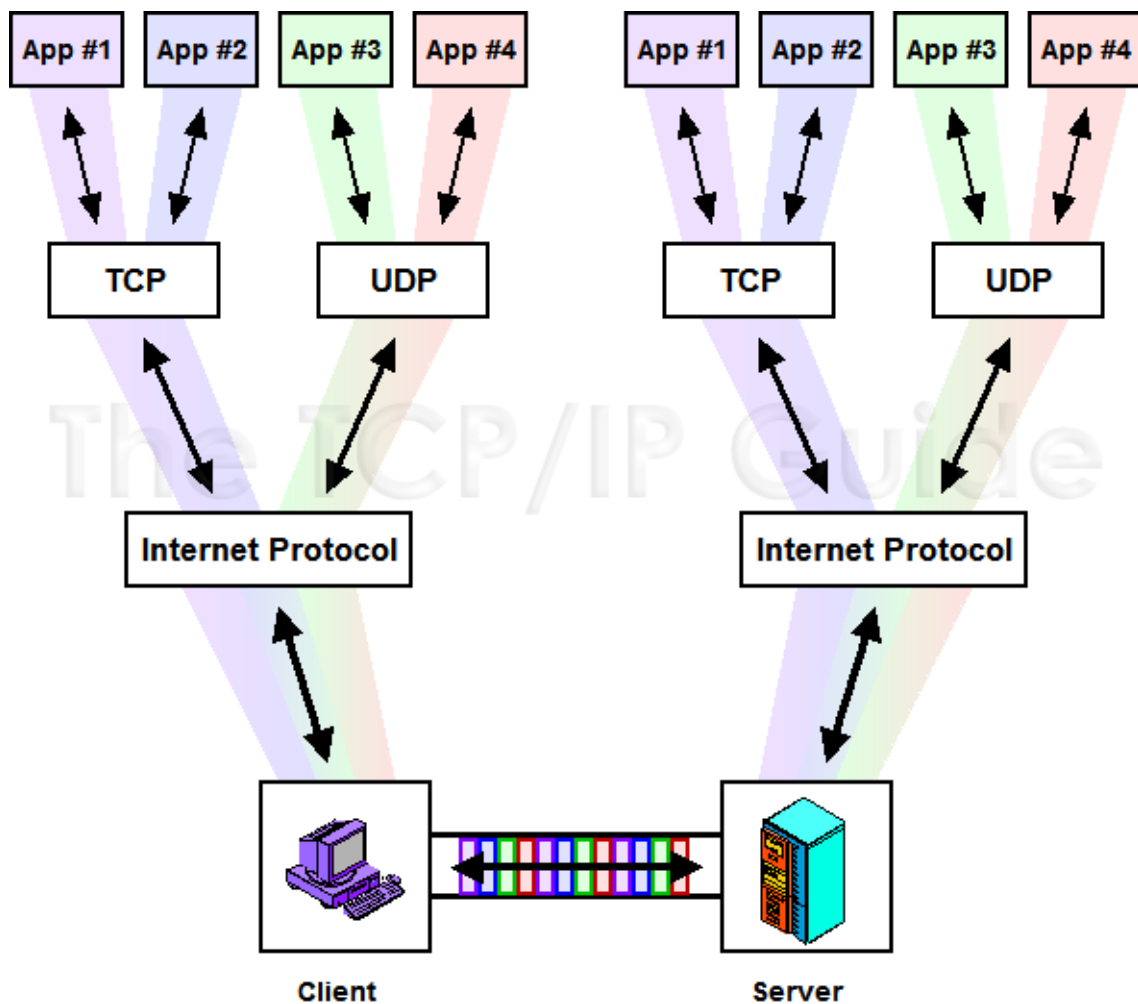

# ports

공존을 허용하는 비밀 병기

(src ip, src port, dest ip, dest port)

# + port #

여러 대의 컴퓨터에서  
여러 개의 응용 프로그램이  
동시에 서로 통신을 해도  
끼이지 않는다.

# Data Flow

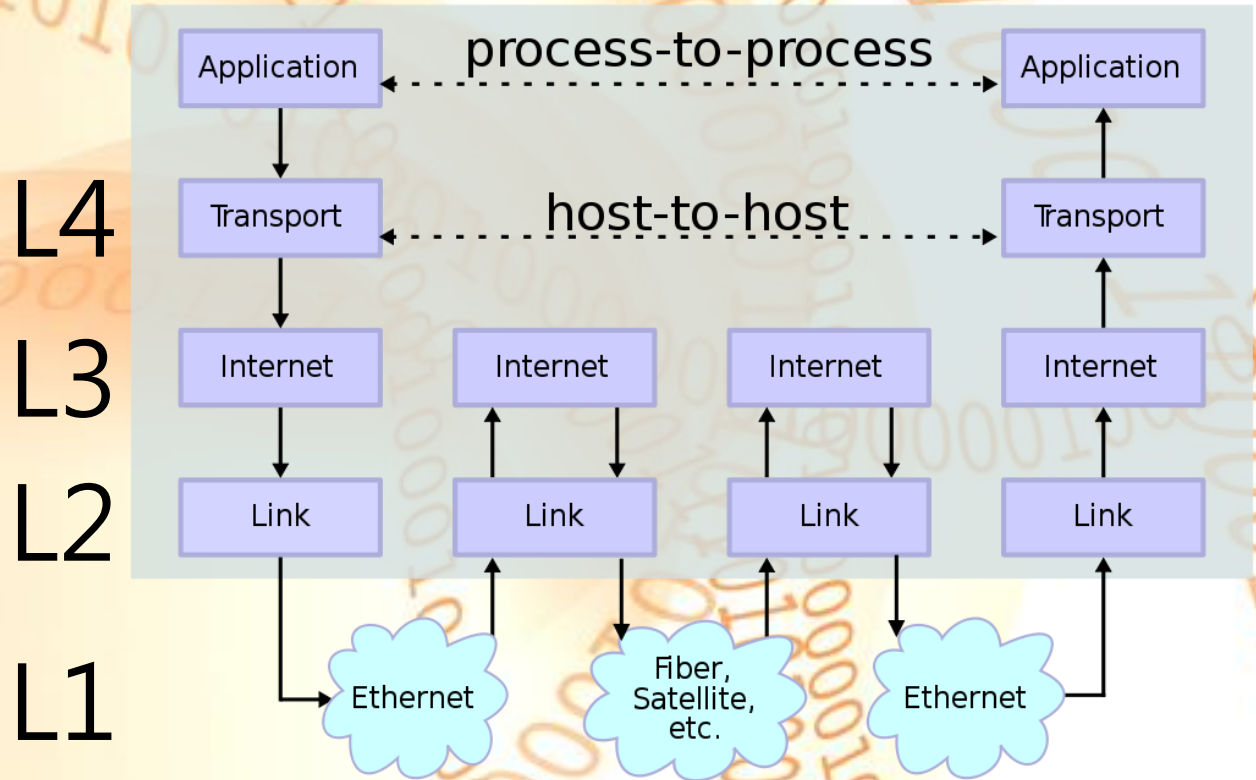

L4는 e2e





# Domain Name Space

폴 모카페트리스(1983)  
hosts 파일 관리를 분산  
시키자.

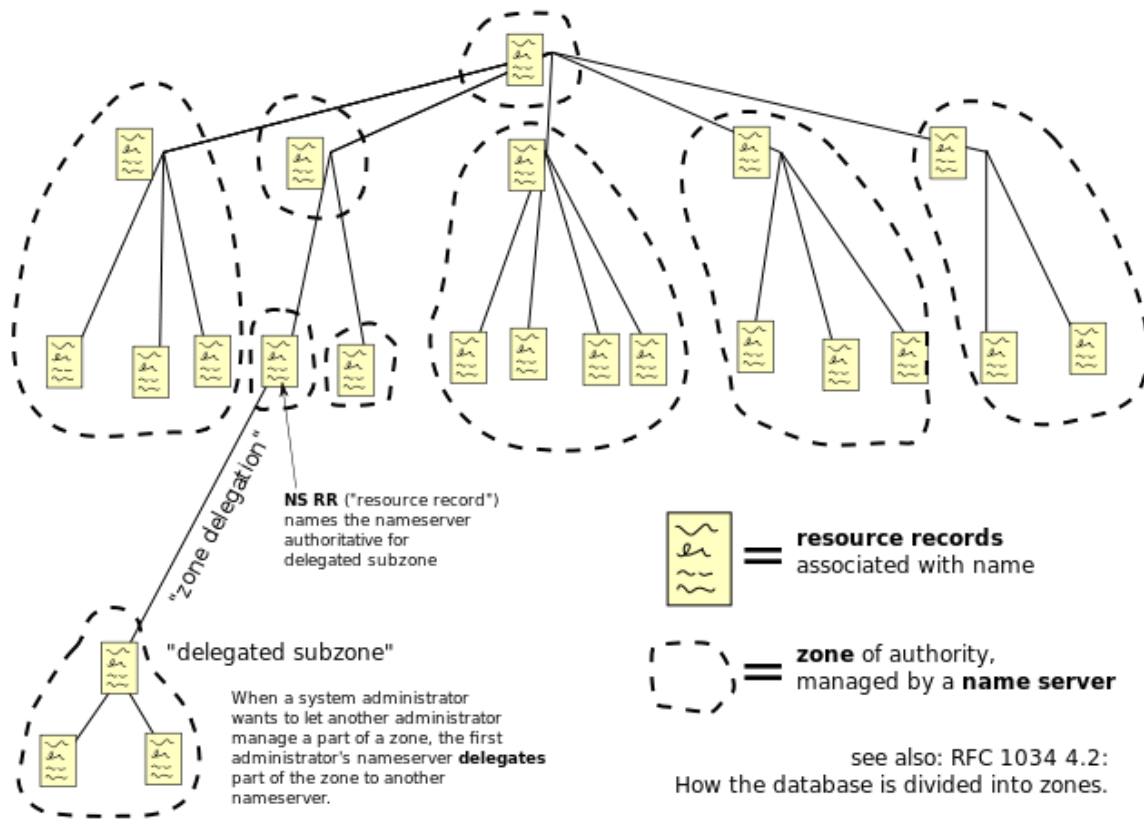

# HOSTS.TXT

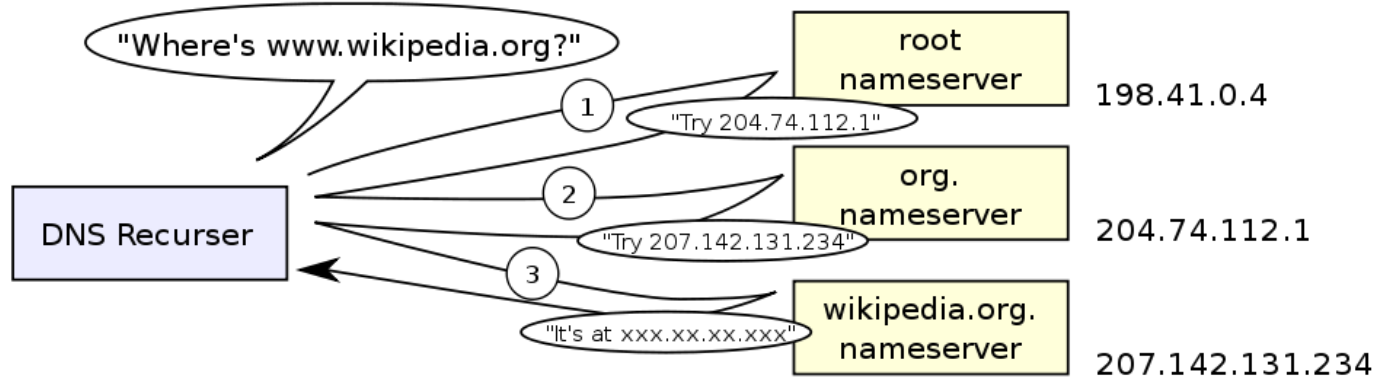

# + DNS

상대방의 IP 주소 대신  
이름을 알면 통신을  
할 수 있게 되었다.

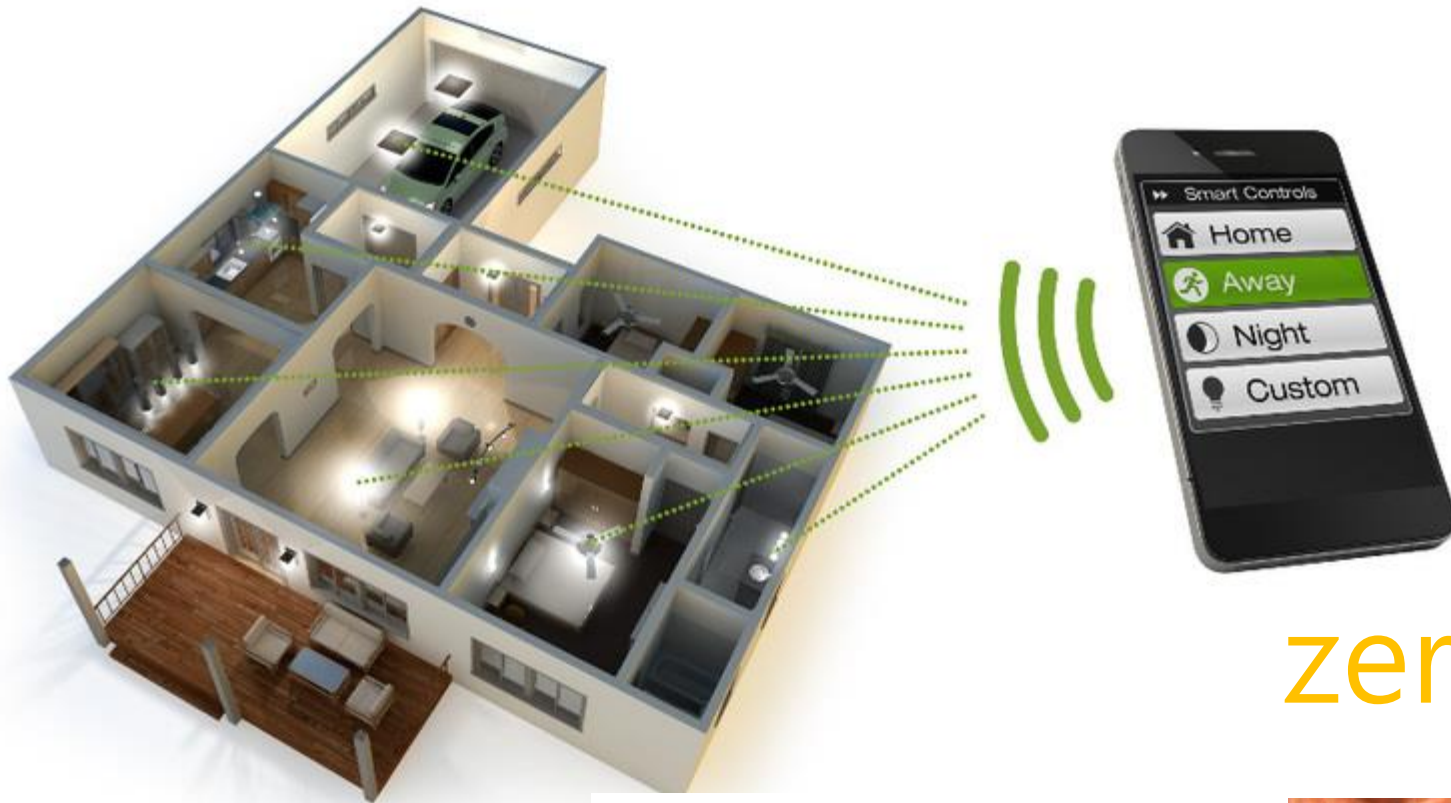

zeroconf

### Smart Dust Mote



그림 출처: <http://inteldigitalreport.com>

그림 출처: <http://binarydissent.com>

# DHCP

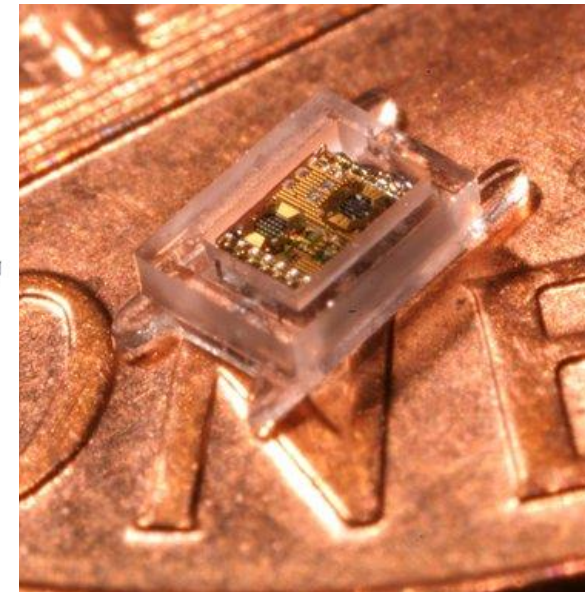
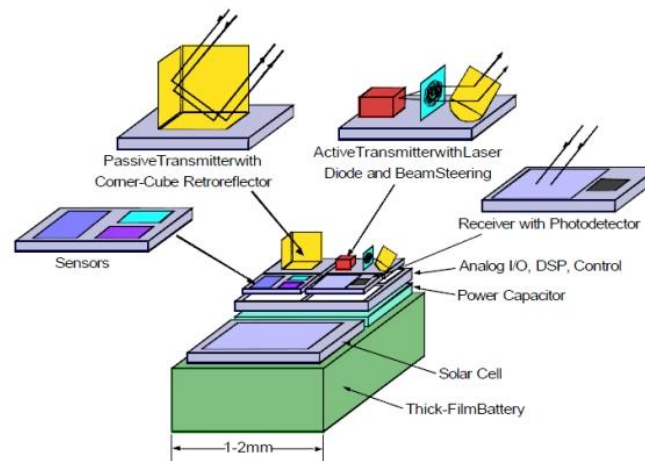
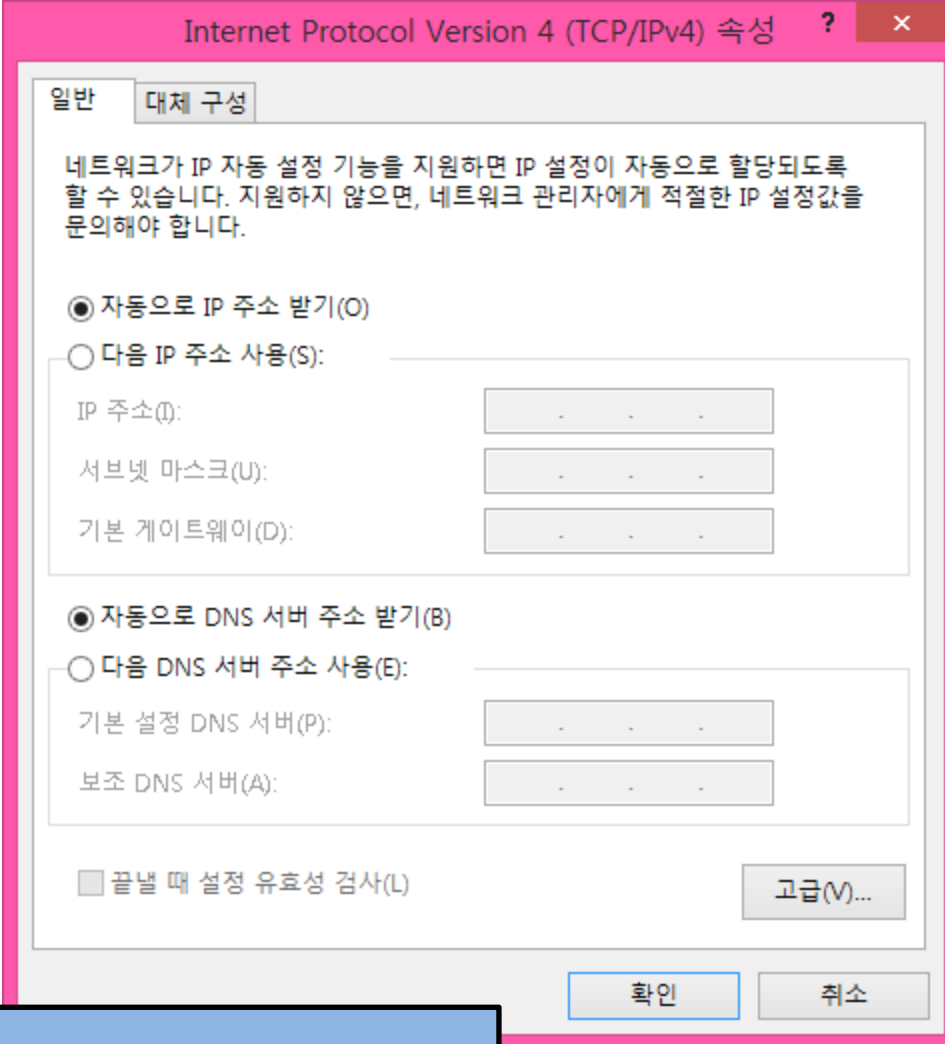

## DHCP 요청

브로드캐스트 주소

네트워크 설정 하는 법 알려줘요

## DHCP 응답

브로드캐스트 주소

상대의 MAC 주소

당신의 IP는 X.X.X.X이고 G/W는...

# NAT

## Public address vs. Private address

10.0.0.0/8 (255.0.0.0)  
172.16.0.0/12 (255.240.0.0)  
192.168.0.0/16 (255.255.0.0)

ISP (ingress) filtering  
127.0.0.1 해킹하지 마세요 ^^





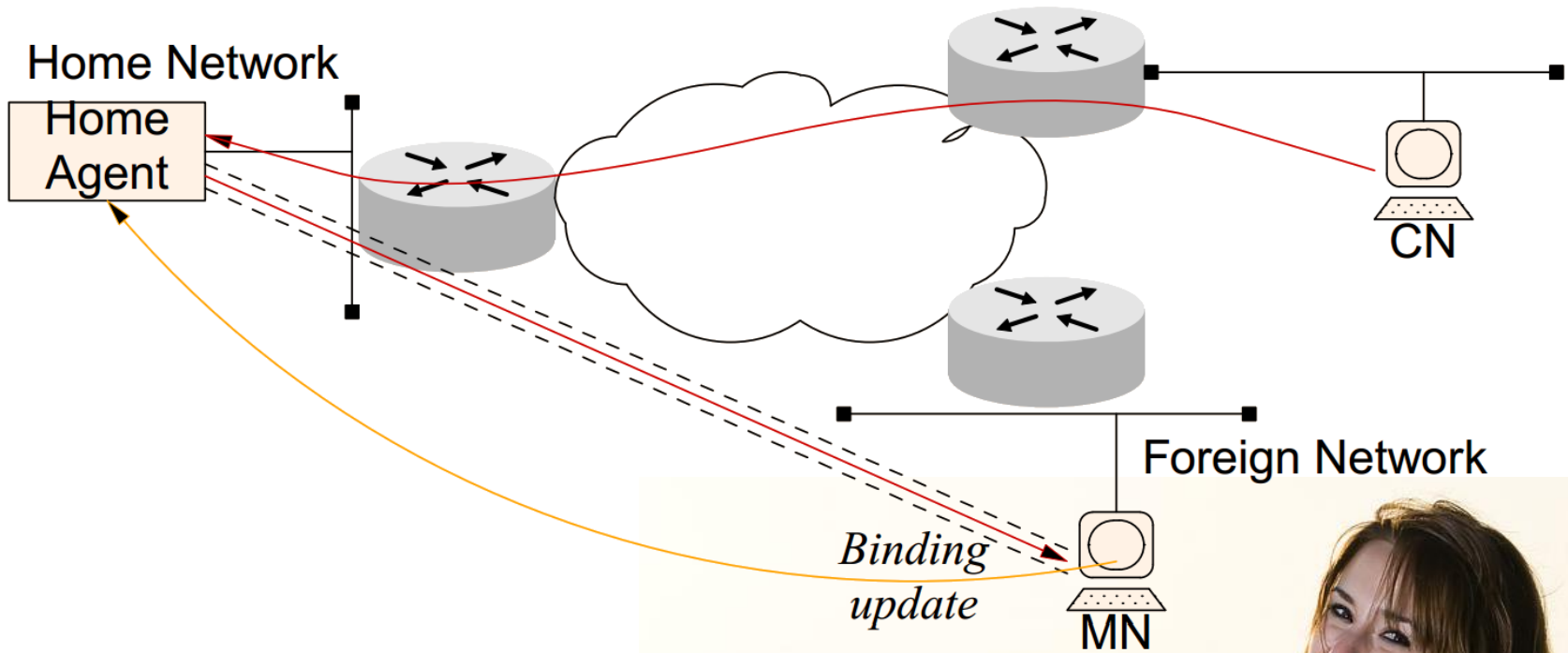

IP tunneling  
 Triangular routing  
 Binding update



# semantic overload

IP address = Locator + Identifier

스마트폰(WIFI+4G) : 같은 기계 다른 주소

DHCP, NAT, proxy : 다른 기계 같은 주소

Mobile IP / Multi homing : 같은 카드 다른 주소



## route aggregation

efficiency vs. flexibility

Provider independent address block



# 25%

북미 ISP의 총 트래픽중 25%은 구글과 연결되는 것  
구글이 소모하는 전기는 원자력 발전소 1기 발전량의 1/4

패킷?  
fiber

평평한 인터넷  
Backbone vs. Google & CDN

Goodbye hosts!  
computing → data → contents  
pull → push

인터넷이 필요한지?  
facebook / kakao

많은 인터넷?  
clean slates / openflow



MATRIX  
RELOADED  
WWW.THEMATRIX.COM

# 창과 방패

[warning.or.kr](http://warning.or.kr)

방화벽

tor, freenet, & ...

정보보안 기본 개념

# KCSC Warning

## 불법·유해 정보(사이트)에 대한 차단 안내

귀하가 접속하려고 하는 정보(사이트)에서 불법·유해 내용이 제공되고 있어 해당 정보(사이트)에 대한 접속이 차단되었음을 알려드립니다.

해당 정보(사이트)는 방송통신심의위원회의 심의를 거쳐 방송통신위원회의 설치 및 운영에 관한 법률에 따라 적법하게 차단된 것이오니 이에 관한 문의사항이 있으시면 아래의 담당기관으로 문의하여 주시기 바랍니다.

사이트분야	담당기관	전화번호
안보위해행위	사이버 경찰청	1566 - 0112
도박	사이버 경찰청	1566 - 0112
	게임물관리위원회	(051)720-6800
음란	방송통신심의위원회	(02)3219 - 5164, 5152
불법 의약품 판매	식품의약품안전처 의약품관리총괄과	(043)719-7000
불법 식품 판매 및 허위과대광고	식품의약품안전처 식품관리총괄과	(043)719-2033
불법 화장품 판매 및 허위과대광고	식품의약품안전처 화장품정책과	(043)719-3407
불법 의료기기 판매	식품의약품안전처 의료기기관리과	(043)719-3762
불법 마약류 매매	식품의약품안전처 마약정책과	(043)719-2810
불법 체육진흥투표권 판매	사행산업통합감독위원회	(02)3704-0538
	국민체육진흥공단 클린스포츠 통합콜센터	1899-1119
불법 승자투표권 구매대행	국민체육진흥공단 경륜사업본부	(02)2067-5813
	국민체육진흥공단 경정사업본부	(031)790-8531

# 어떻게 이 화면이 나오는 걸까요?



```
$ dig sora.net
```

```
; <<>> DiG 9.8.1-P1 <<>> sora.net
;; global options: +cmd
;; Got answer:
;; ->>HEADER<<- opcode: QUERY, status: NOERROR, id: 7406
;; flags: qr rd ra; QUERY: 1, ANSWER: 1, AUTHORITY: 0, ADDITIONAL: 0

;; QUESTION SECTION:
;sora.net.                IN      A

;; ANSWER SECTION:
sora.net.                100    IN      A      69.197.27.194

;; Query time: 210 msec
;; SERVER: ??????????????????????
;; WHEN: Sat Jan 11 17:09:52 2014
;; MSG SIZE rcvd: 42
```

```
$ telnet 69.197.27.194 80
Trying 69.197.27.194...
Connected to 69.197.27.194.
Escape character is '^]'.
GET / HTTP/1.1
Host: sora.net
HTTP/1.0 302 Redirect
Location: http://www.warning.or.kr

Connection closed by foreign host.
```

# 왜 우리는 언니들을 만날 수 없나?

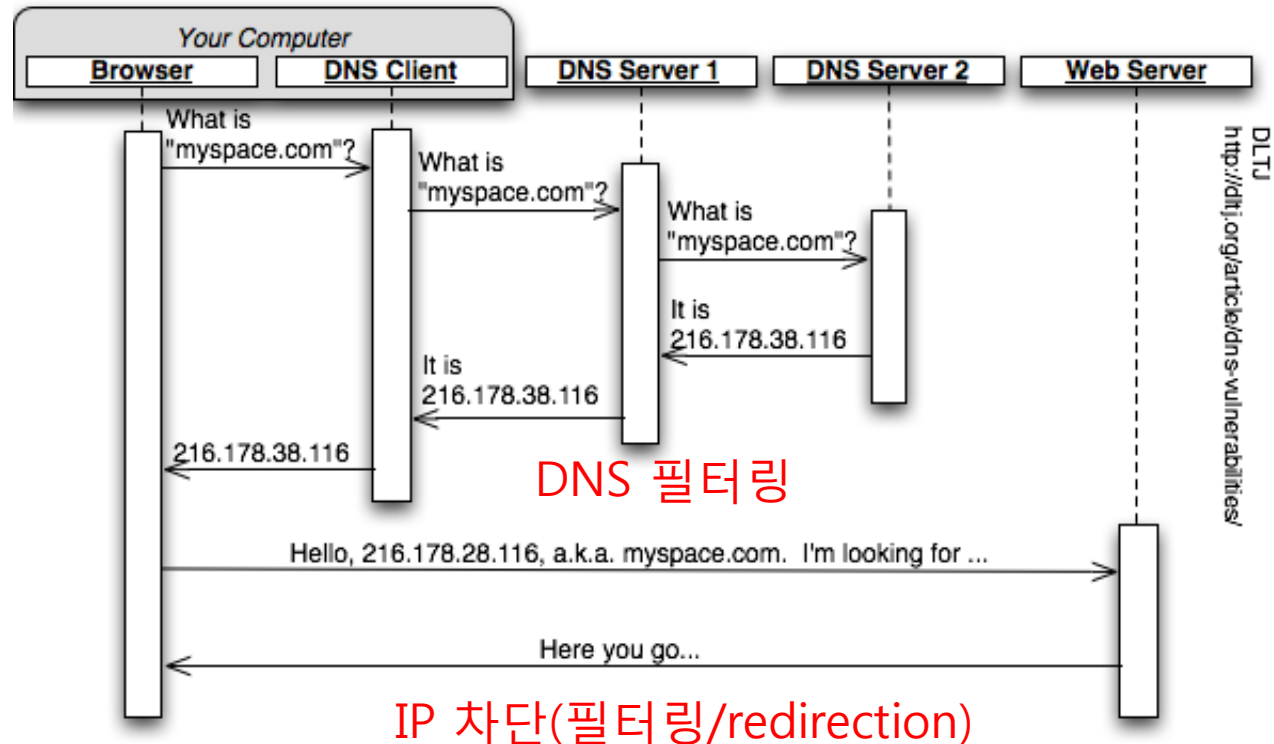

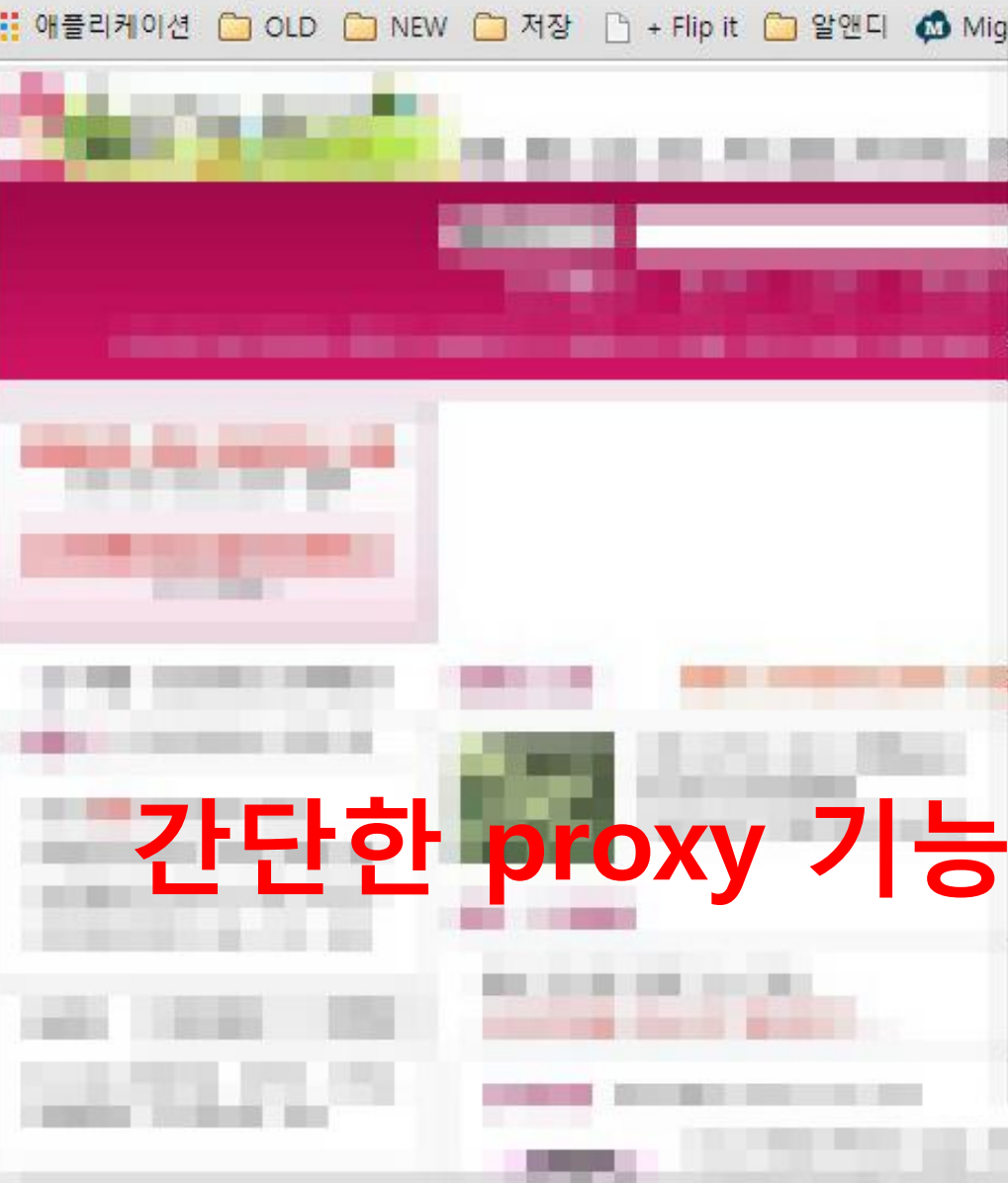
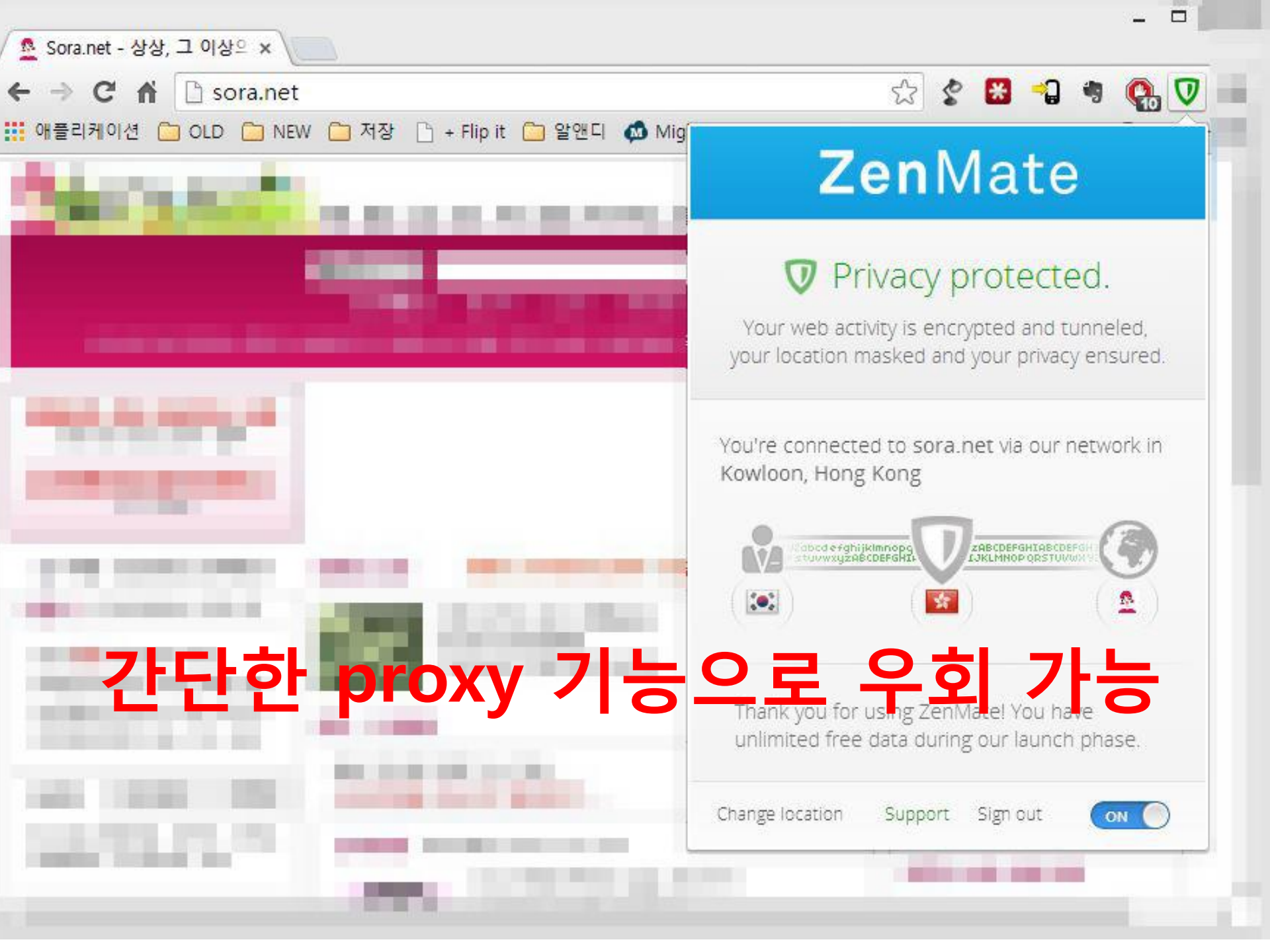

# ZenMate

Privacy protected.

Your web activity is encrypted and tunneled, your location masked and your privacy ensured.

You're connected to sora.net via our network in Kowloon, Hong Kong

abcdefghijklmnopqrstuvwxyz
ABCDEFGHIJKLMNOPQRSTUVWXYZ

# 간단한 proxy 기능으로 우회 가능

Thank you for using ZenMate! You have unlimited free data during our launch phase.

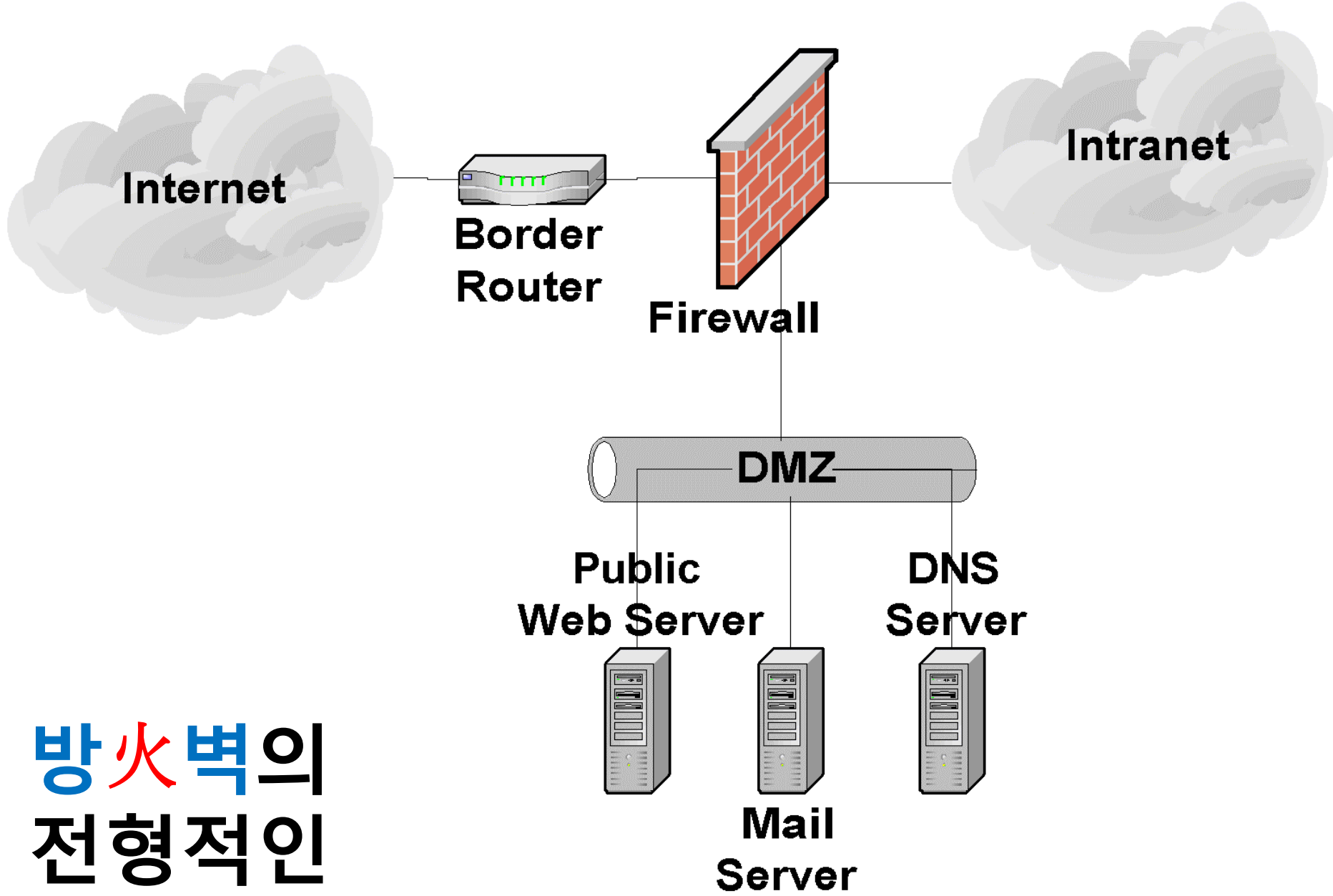

**방**火**벽**의  
전형적인  
構成**방식**

그림 출처: <http://www.totalroute.net/cgi-web-hosting/CGI-Web-Hosting-Guidelines0080.htm>

# Firewall systems

## Types and operation

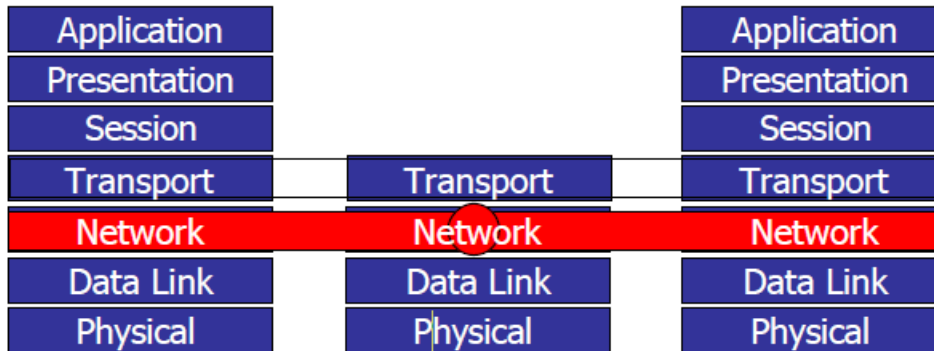

Packet level filtering

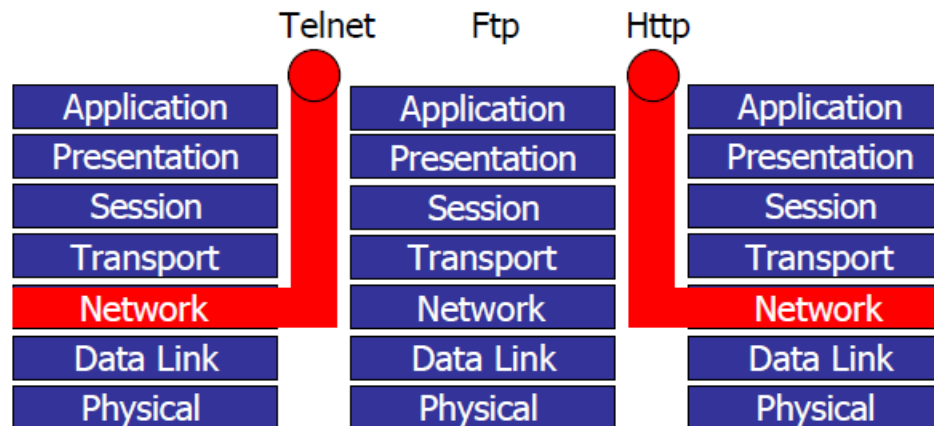

Application level filtering

방화벽의  
동작방식



# 방화벽 공격기법

- Packet fragmentation
- Source porting
- Source routing
- Vulnerabilities in TCP/IP stack
- FTP PASV
- External (e.g. **outsourced**) systems
- Content (e.g. **email**-borne trojan horse)
- Man in the middle attacks (e.g. compromised **DNS**)
- 출처: POL34CERT

유생전(劉生展) 作, 현대 중국, <유비·관우·장비 삼 형제와 싸우는 여포>

# 방화벽의 진화

그림 출처: [http://enterprise.huawei.com/topic/2013\\_Firewall\\_en/index.html](http://enterprise.huawei.com/topic/2013_Firewall_en/index.html)

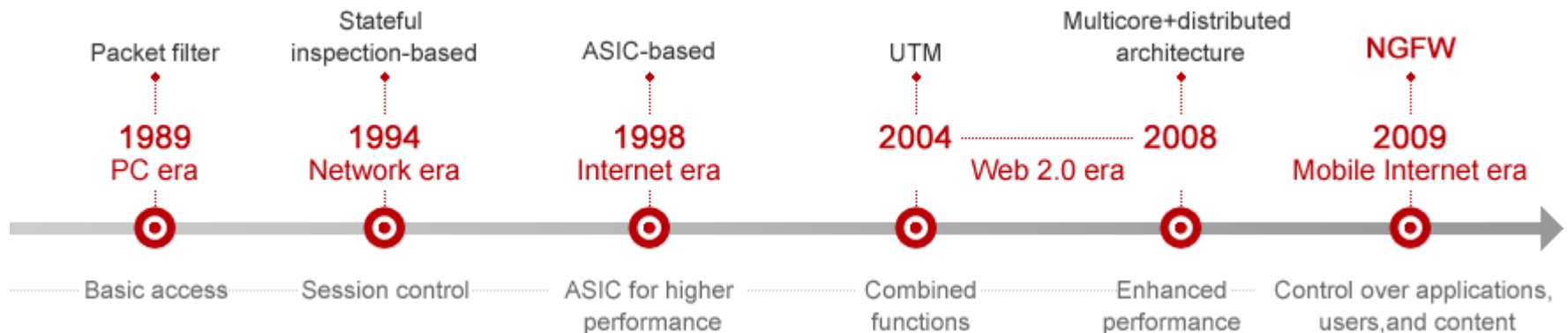



# Edward Snowden



Latest on the computer analyst whistleblower who provided the Guardian with top-secret NSA documents leading to revelations about US surveillance on phone and internet communications

## Top story



### Mass surveillance by security services should be reviewed, say Lib Dems

8 Jan 2014: Party's motion, in wake of Snowden whistleblowing, covers agencies' accountability, data collection and bill of rights  
191 comments

## The NSA files whistleblower

### 'They will say I aided our enemies'

Video (7min 07sec): The

## Most recent

### Liberal Democrats: digital drumbeat

9 Jan 2014: Editorial: Two senior Liberal Democrats call for judicial oversight of state surveillance and regular releases of statistics on UK security service data requests  
41 comments

### European parliament invites Edward Snowden to testify via video

9 Jan 2014: Not yet clear if NSA whistleblower will accept invitation from European parliament committee investigating surveillance

### Mass surveillance by security services should be reviewed, say Lib Dems



8 Jan 2014: Party's motion, in wake of Snowden whistleblowing, covers agencies' accountability, data collection and bill of rights  
191 comments

# 2014 or 1984



# 인터넷에서의 익명성

Tor  
Freenet  
I2P  
GNUnet  
nightweb

## Anonymity Online

Protect your privacy. Defend yourself against network surveillance and traffic analysis.



Download Tor

- Tor prevents people from learning your location or browsing habits.
- Tor is for web browsers, instant messaging clients, and more.
- Tor is free and open source for Windows, Mac, Linux, and BSD.



Freenet  
THE FREE NETWORK

### What is Tor?

Tor is free software and an open network that helps you defend against traffic analysis, a form of network surveillance that threatens personal freedom and privacy, confidential business activities and relationships, and state security.

[Learn more about Tor »](#)

### Why Anonymity?

Tor protects you by keeping your communications around the world anonymous. Tor relays run by volunteers prevent somebody you connect to from learning your connection from learning your location and it prevents the site you visit from learning your physical location.

## Share, Chat, Browse. Anonymously. On the Internet.

Share files, chat on forums, browse and publish, anonymously and without fear of blocking or censorship! Then connect to your friends for even better security!

[Learn more!](#)



Freenet  
Download  
0.7.5 for Windows

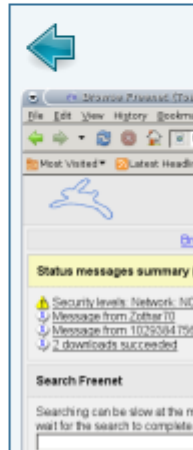

보안의  
목표와  
구분

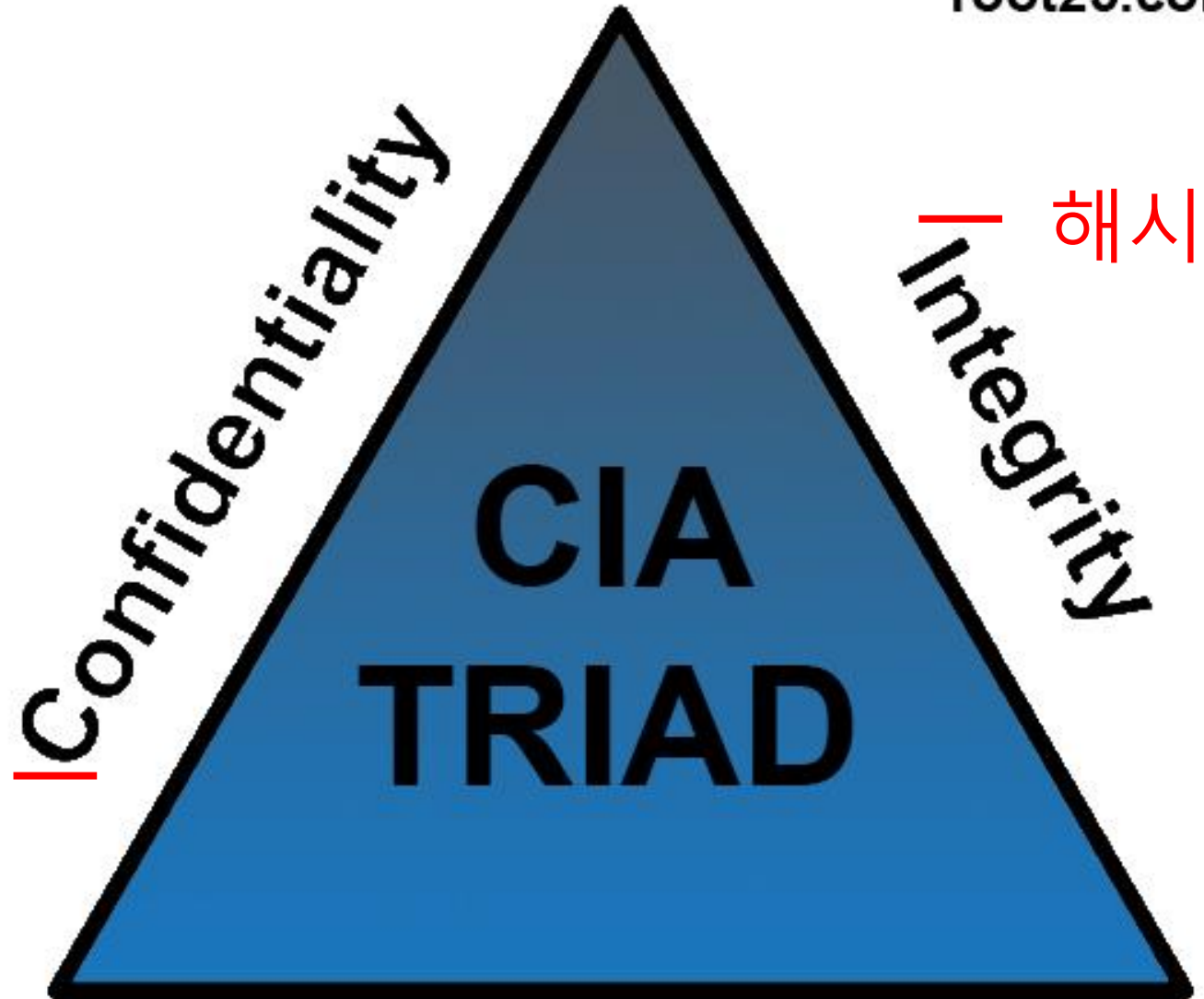

암호  
대칭/비대칭

해시  
Integrity

message digest,  
authentication,  
authorization,  
certificate, PKI

DoS Availability